

**REMEDICATION OF SOIL AND GROUNDWATER
BY
VACUUM ENHANCED RECOVERY**

By

Marco Nardone

**A project paper submitted to the
College of Graduate Studies and Research through
Civil and Environmental Engineering
in partial fulfilment of the requirements for the
Degree of Master of Applied Science
at the University of Windsor**

**Windsor, Ontario, Canada
April, 2000**



National Library
of Canada

Acquisitions and
Bibliographic Services

395 Wellington Street
Ottawa ON K1A 0N4
Canada

Bibliothèque nationale
du Canada

Acquisitions et
services bibliographiques

395, rue Wellington
Ottawa ON K1A 0N4
Canada

Your file Votre référence

Our file Notre référence

The author has granted a non-exclusive licence allowing the National Library of Canada to reproduce, loan, distribute or sell copies of this thesis in microform, paper or electronic formats.

The author retains ownership of the copyright in this thesis. Neither the thesis nor substantial extracts from it may be printed or otherwise reproduced without the author's permission.

L'auteur a accordé une licence non exclusive permettant à la Bibliothèque nationale du Canada de reproduire, prêter, distribuer ou vendre des copies de cette thèse sous la forme de microfiche/film, de reproduction sur papier ou sur format électronique.

L'auteur conserve la propriété du droit d'auteur qui protège cette thèse. Ni la thèse ni des extraits substantiels de celle-ci ne doivent être imprimés ou autrement reproduits sans son autorisation.

0-612-52619-4

Canada

ABSTRACT

A literature review and case study of Vacuum Enhanced Recovery (VER) technology, also known as bioslurping, is presented in this project paper. The literature review was conducted to investigate historic and current VER design and pilot study practices. The case study presents the field activities and results of an actual VER pilot study conducted at an operating retail petroleum facility. The results of the pilot study were used to assess the feasibility of VER technology to remediate hydrocarbon impacted soil and groundwater and to design a full scale VER system for the site.

The pilot study results indicated a high level of contaminant mass removal from the subsurface and a large zone of groundwater influence. Consequently, VER was deemed an acceptable remediation technology for the case site. The full scale system was designed to draw 8.60 am³/min (300 acfm) of air and 57 Lpm of water from the subsurface at an operating vacuum of 457 mm Hg. (18 in. Hg). The system employed a 30 hp oil-sealed liquid vacuum pump attached to eight individually plumbed extraction wells. An initial mass removal rate of 1,430 kg/day of total petroleum hydrocarbons was estimated.

VER is a relatively new subject in the field of remediation engineering. Additional research should focus on methods to limit the uncertainty in design due to site-specific heterogeneities, less onerous methods of applying numerical modeling to simulate multi-phase flow in the subsurface, and additional case studies to improve pilot study protocol and VER system design.

ACKNOWLEDGEMENTS

It has been an enduring task to complete my Masters of Applied Science degree program while working full time and moving across the country. I could not have done it without the help of my friends and colleagues.

I wish to thank Shannon Orr for her endless encouragement and support.

I would also like to thank Dr. Stan Reitsma and Dr. N. Biswas for their guidance, advice and patience. A sincere “thank you” to David Cushman and Stephen Ball for their contributions to this project and allowing flexibility in my work schedule to complete my degree.

TABLE OF CONTENTS

ABSTRACT	iii
ACKNOWLEDGEMENTS	iv
LIST OF TABLES	viii
LIST OF FIGURES	ix
1 INTRODUCTION	1
2 LITERATURE REVIEW	5
2.1 VER Principles	5
3 CASE STUDY	18
3.1 Site Overview	18
3.2 Pilot Study Equipment	21
3.3 Extraction Well Construction	23
4 PILOT STUDY OBSERVATIONS	24
4.1 Test 1: Extraction from a 2-inch Diameter Well	24
4.1.1 Pilot System Data	24
4.1.2 Monitoring Point Data	25
4.2 Test 2: Extraction from a 100-mm Diameter Well	28
4.2.1 Pilot System Data	28
4.2.2 Monitoring Point Data	30
5 MASS REMOVAL ESTIMATES	33
5.1 Vapour Phase Mass Removal Rate	33
5.2 Liquid Phase Mass Removal Rate	35
5.3 Total Mass Removal Rate	36
6 CONCEPTUAL DESIGN OF VER SYSTEM	38
6.1 Design Summary	38
6.2 Mass Removal Estimates	41
6.3 System Components	41
6.3.1 Recovery Wells	41
6.3.2 Well Head Construction	42
6.3.3 Liquid Ring Vacuum Pump	42
6.3.4 Vapour/Liquid Separator	42

6.3.5	Recovered Liquids Transfer Pump	43
6.3.6	Oil/Water Separator	43
6.3.7	Low Profile Air Stripper	44
6.3.8	System Protection	44
6.3.9	System Controls	45
6.4	Mechanical and Electrical	46
6.4.1	Piping	46
6.4.2	Fittings and Valves	47
6.4.3	Electrical	47
7	CONCLUSION	48
8	REFERENCES	50
	VITA AUCTORIS	52

LIST OF TABLES

Table 1	VER Pilot System Data (TEST 1)
Table 2	Monitoring Point Data (TEST 1)
Table 3	Water Level Data (TEST 1)
Table 4	VER Pilot System Data (TEST 2)
Table 5	Monitoring Point Data (TEST 2)
Table 6	Water Level Data (TEST 2)
Table 7	Summary of Extracted Vapour Analytical Results
Table 8	Summary of Extracted Groundwater Analytical Results
Table 9	Petroleum Hydrocarbon Mass Removal Estimates

LIST OF FIGURES

Figure 1	Site Plan
Figure 2	TPH Isopleths
Figure 3	Air Flow Rate and Vacuum vs. Time (TEST 1)
Figure 4	Groundwater Flow Rate vs. Time (TEST 1)
Figure 5	Oxygen and Vapour vs. Time (TEST 1)
Figure 6	Induced Vacuum (TEST 1)
Figure 7	Headspace Vapour Concentrations (TEST 1)
Figure 8	Headspace Oxygen Concentrations (TEST 1)
Figure 9	Induced Vacuum vs. Distance (TEST 1)
Figure 10	Drawdown vs. Distance (TEST 1)
Figure 11	Air Flow Rate and Vacuum vs. Time (TEST 2)
Figure 12	Groundwater Flow Rate vs. Time (TEST 2)
Figure 13	Oxygen and Vapour vs. Time (TEST 2)
Figure 14	Induced Vacuum (TEST 2)
Figure 15	Headspace Vapour Concentrations (TEST 2)
Figure 16	Headspace Oxygen Concentrations (TEST 2)
Figure 17	Induced Vacuum vs. Distance (TEST 2)
Figure 18	Drawdown vs. Distance (TEST 2)
Figure 19	Bioslurping System Schematic
Figure 20	Predicted Areas of Groundwater and Vapour Influence
Figure 21	Extraction Well Details

1 INTRODUCTION

Petroleum product releases are a common cause of groundwater and soil contamination. Hydrocarbon constituents typically partition into four distinct yet interrelated phases; non-aqueous phase liquids (NAPL) adsorbed to saturated or unsaturated soil particles, free phase NAPLs, soluble constituents dissolved in the groundwater, and volatile constituents in the soil pore space of the vadose zone. Since these four phases are related by equilibrium partitioning, and interphase mass transfer, effective site investigation and remediation activities must address each phase. In addition, since timely, economic site restoration will ultimately depend on maximizing mass removal of the constituents in each phase, the selected remedy must not only address each constituent phase, but address each in the most efficient manner with respect to the rate of mass removal (Hansen, et. al., 1994).

Various technologies are available for the remediation of subsurface petroleum contamination. Some technologies focus specifically on the remediation of a single phase of contamination (dissolved phase, adsorbed phase, vapour phase or free product) whereas others are capable of remediating multiple phases simultaneously. Conventional groundwater pump and treat technology has been applied at numerous sites to reduce dissolved phase contaminants in the subsurface. The basis of this technology is the extraction of groundwater from the subsurface using submersible pumps, surface pumps or pneumatic pumps and treating the groundwater on the surface. Pump and treat activities have received much criticism over the past decade because, in many cases, the actual

benefits gained from the technology are far outweighed by the costs. Due to the excessive costs associated with this technology, pump and treat operations tend to be limited to projects where there is an imminent or projected health risk associated with exposure to contaminated water. The effectiveness of conventional pump and treat technology is limited in low transmissivity soils and thin saturated zones. These conditions result in small capture zones thereby requiring numerous recovery wells (Granskog et al., 1994).

Vacuum enhanced recovery (VER) technology, also known as bioslurping, has been successfully used to remediate petroleum contamination (free phase, adsorbed phase, dissolved phase and vapour phase) at numerous sites across North America. This technology involves the application of a medium to high vacuum to both the saturated and unsaturated soil zones to recover petroleum contamination. The applied vacuum tends to draw contaminants, including contaminants previously trapped in fractures, into the extraction point for recovery. This technology is particularly suited for remediating low permeable formations such as silts, clays, saprolites and bedrock. VER is a custom practice in the construction industry (Powers, 1981). The technology was revitalized in the environmental industry to control and recover petroleum hydrocarbons in groundwater (Blake et. al., 1989).

VER technology offers several distinct advantages for addressing petroleum contamination. First, it is typically much more effective at recovering petroleum contamination in low permeable formations than traditional pump and treat methods (including free product skimmer pumps). Second, the remediation is *in situ*, thereby causing minimal disturbance to regular operations at the subject property. Third, the costs

associated with the technology (both capital and operation and maintenance costs) are comparable to other applicable technologies. Fourth, the increased movement of air (oxygen) in the subsurface enhances the potential for indigenous biodegradation of the contaminants, thereby accelerating the remediation process.

One disadvantage associated with VER technology is the generation of a wastewater stream which results in higher capital and maintenance costs, as well as more stringent institutional requirements, ie. discharge permits. A second disadvantage associated with bioslurping is the occurrence of channeling. Channeling occurs when contamination is recovered from preferential migration pathways in the subsurface. Channeling may result in only the partial recovery of contaminated soil vapours and groundwater, thus minimizing the effectiveness of the remediation. The effects of channeling may be reduced by cycling or pulsing the extraction system on and off rather than operating continuously.

Extracted petroleum vapours from VER systems may be discharged directly to the atmosphere if concentrations are sufficiently low and appropriate regulatory approvals have been granted. Alternatively, the extracted vapours may be treated. Vapour treatment may be accomplished using vapour phase carbon adsorption, internal combustion, catalytic/thermal oxidation, bioremediation or combinations thereof. Extracted groundwater may also require treatment depending on applicable regulatory requirements for the site.

The objectives of this project were to:

- (1) provide technical and historical background information on VER technology;

- (2) discuss practical methods for designing VER systems for the remediation of petroleum contaminated soil and groundwater;
- (3) outline VER pilot study methodology; and
- (4) provide an example pilot study and conceptual VER system design.

The scope of work for this project entailed the following tasks:

- (1) Conduct a literature review on VER technology and common practices associated with designing VER systems;
- (2) Present current information on VER pilot study methodology; and
- (3) Present a case study of actual VER pilot study results and full scale system design.

2 LITERATURE REVIEW

2.1 VER Principles

All liquid recovery remediation systems operate by removing groundwater or NAPL at a controlled rate, thereby creating a hydraulic gradient toward the recovery well. The area within which the NAPL or groundwater moves toward the recovery well is defined as the *capture zone* (Suthersan, 1997). The capture zone of a particular recovery well is limited by the transmissivity (the rate at which water moves through a unit thickness of the aquifer) of the formation and the existing natural gradient. Typically, the capture zone can be increased by increasing the extraction rate from the recovery well. However, the extraction rate is limited by the maximum allowable drawdown in the well which cannot exceed the saturated thickness of the aquifer. Drawdown is defined as the difference between the static water level (no pumping) and dynamic water level (during pumping) in the recovery well. The hydraulic gradient cannot be increased by increasing the pumping rate if drawdowns have reached their limiting value (Ayyaswami, 1994).

As mentioned previously, VER is a technique of applying a high vacuum or negative pressure on a recovery well and the formation. By applying a vacuum, the transmissivity of the aquifer and the hydraulic gradient toward the recovery well are increased by increasing the net effective drawdown. The net effective drawdown is the difference between the static and dynamic water level in the recovery well plus the amount of vacuum that is applied to the subsurface. The increased transmissivity and drawdown results in a corresponding increase in the rate of groundwater extraction (yield). This is the

fundamental principle behind VER systems (Suthersan, 1997). In addition, vacuum-enhanced pumping promotes continuity in the NAPL phase, ie. lower capillary pressure and fewer air pockets in the capillary fringe (Battelle, 1996).

Increased groundwater extraction rates and residual NAPL recovery through the use of VER has been reported by Blake and Gates (1986). Reisinger et al. (1993) reported enhancing groundwater extraction by a factor of 47% as a result of vacuum extraction (Battelle, 1996).

NAPL recovery is often attempted by using skimming or drawdown pumping techniques. Preliminary data from short-term bioslurper tests conducted by Battelle for the Air Force Center for Environmental Excellence (AFCEE) and the NFESC indicate that the NAPL recovery rate by bioslurping is up to six times the rate of skimming and as much as twice the rate of drawdown pumping (Battelle, 1996). Mathematical modeling programs comparing conventional pumping technology to bioslurping have predicted that free product mass removal from the affected soils will be twice as fast when bioslurping technology is used (Parker, 1995). Furthermore, the total volume of groundwater pumped, and hence the water treatment costs, may be substantially less with bioslurping systems than with conventional serial technology applications (Barnes and McWhorter, 1995).

The lifting height of groundwater via suction may appear to be a limitation of VER technology. In theory, the suction lift attainable with an extremely efficient vacuum pump is approximately 7.6 metres (25 feet), depending on elevation (Powers, 1981). However, lifts greater than the theoretical maximum can be attained when the extracted fluid is not

only water, but a mixture of soil gas and groundwater (Powers, 1981). A mixture of soil gas, water and NAPL has a specific gravity less than one and, therefore, can be lifted higher than a standard water column (Battelle, 1996). Another phenomenon that can help achieve greater than theoretical suction lift is liquid entrainment or entrapment which occurs when the primary extraction fluid is soil gas, rather than a liquid (Battelle, 1996). At high velocities, extracted soil gas can entrain water droplets and carry them to the surface via slug flow at high liquid extraction rates. A vertical air flow velocity of 914 metres per minute) should be applied to ensure sufficient lift (Suthersan, 1997).

VER also increases the mass removal of volatile and semi-volatile contaminants by maximizing dewatering and facilitating volatilization from previously saturated sediment via the increased air movement. In addition, the mass removal of aerobically biodegradable contaminants will be enhanced by the resulting increase of subsurface oxygen levels (Suthersan, 1997). The air flow created by the vacuum also causes NAPL to flow towards the well. The pressure gradient created in the air phase results in a driving force on the NAPL that is significantly greater than that which can be induced by pumping the NAPL with no air flow. Also of importance is the fact that the air flow created by the vacuum actually increases the NAPL content around the well. That is, the NAPL tends to accumulate around the well so that it is easily extracted (Battelle, 1996).

VER is not applicable in every situation. The technology is limited in use to specific geological and hydrogeological settings within a limited range of conditions. Based on data collected from numerous applications of VER systems under different hydrogeological conditions, some basic guidelines have been developed (Blake et. al.,

1989). VER systems are normally considered as a remedial option for the following conditions (Suthersan, 1997):

- Low transmissivity formations (less than 6200 litres per day per metre [lpd/m]:
- Low hydraulic conductivities (from 10^{-2} to 10^{-4} millimetres per second [mm/s]. may be possible at less than 10^{-5} mm/s if some secondary permeability exists);
- Perched NAPL and groundwater layers;
- Total fluids recovery in low permeability formations;
- Formations consisting of interbedded sand and clay layers;
- Formations with limited saturated thickness; and
- Low permeability fractured systems.

A thorough understanding of site conditions, combined with properly performed, site-specific pilot studies are essential to designing an effective full scale VER system. The following subsection outlines the protocol for a VER pilot study.

2.2 VER Pilot Study Protocol

The objectives of VER pilot studies should be to: (1) determine the effectiveness of the VER technology to remediate all phases of the subsurface petroleum contamination to acceptable levels; (2) determine the approximate time required to reduce petroleum hydrocarbon concentrations below the applicable criteria; and (3) obtain data necessary to design an effective and efficient remediation system.

Prior to conducting a VER pilot study, sufficient site characterization data must be obtained to determine if the pilot study is worthwhile and, if so, to design an effective pilot study strategy. If geologic characteristics vary significantly at the site, pilot studies at more

than one location may be required (Battelle, 1996).

Typical site characterization requirements include an understanding of the original contaminant release(s), characterization and volume estimates of the contaminants of concern (COCs), geological and hydrogeological characteristics, physical soil parameters, ie. moisture content, particle size, lateral and vertical extents of the COCs, risk associated with surrounding land use requirements, and relevant government and third party concerns.

In order to design an effective and efficient VER remediation system, the following design parameters must be determined through data collected during the pilot study:

- Zone of groundwater influence;
- Zone of vapour (vacuum) influence;
- Initial NAPL recovery rate;
- Aerobic biodegradation rates;
- Total petroleum hydrocarbons mass removal rate;
- Potential for channelling or short circuiting;
- Extracted air flow rate;
- Extracted groundwater flow rate; and
- Maximum vacuum that can be applied to the subsurface.

Based on the above parameters, the following design criteria can be established:

- Number and spacing of extraction wells;
- Optimum extraction well design;
- Sizing of VER system equipment;
- Extracted groundwater treatment requirements;

- Extracted vapour treatment requirements;
- Aerobic biodegradation potential; and
- Time required for remediation.

It should be noted that the pilot study results may, in fact, indicate that VER technology is not an appropriate remediation alternative for the site.

The planning phase is extremely important to a successful pilot study. Critical issues to consider include selection of the test location (on the site) and duration, extraction well construction details, the number and spacing of extraction and observation wells to be used during the test, and data to be collected during the test (Sittler et. al., 1993).

The test location should have geological characteristics representative of the site and the entire impacted area. It may be necessary to perform multiple tests if the site geology is very heterogeneous. Typically, in most small, well assessed sites, a satisfactory design study can be run for approximately eight to ten hours. Larger, more complex sites require longer test. Most tests should be able to be completed with 24 to 48 hours (Sittler et. al., 1993). Other sources state that the pilot test should be operated for at least five days, or as long as four weeks (Battelle, 1996).

Depending on the site hydrogeological conditions, it is recommended that at least four monitoring wells be installed at 3, 9, 15, and 30 metres away from the test recovery well. Special attention must be given to the design of the monitoring wells to ensure that they are screened at the appropriate depth to facilitate the measurement of the pilot study parameters (Suthersan, 1997). It is also recommended that monitoring wells be installed

with the screened intervals at varying depths. The deepest screen should be placed such that the top of the screen is located approximately one metre above the water table or liquid interface. The shallowest screen should be placed 1 to 1.5 metres below land surface in the vadose zone (Battelle, 1996).

The recovery well should be installed in the impacted area and should be screened both in the unsaturated and saturated zones. The recommended diameter of the extraction well is either 50mm or 100mm. The well should be constructed of schedule 40 polyvinyl chloride (PVC), and screened with a slot size that will minimize the transport of soil fines into the well. Hollow stem auguring is the recommended drilling method. Whenever possible, the diameter of the annular space should be at least twice the diameter of the wells outside diameter. The annular space should be filled with clean silica sand and sealed with a wet bentonite grout (Battelle, 1996).

Prior to initiating the pilot test, baseline data must be collected from the monitoring wells. Baseline data typically includes the following:

- Headspace combustible vapour concentrations;
- Headspace oxygen concentrations;
- Depth to water; and
- Distance from extraction point.

During the pilot study, data is obtained periodically from the monitoring wells and from the pilot system. Parameters measured at the monitoring wells during the test are: (1) induced vacuum responses; (2) headspace combustible vapour concentrations; (3) headspace oxygen concentrations; (4) headspace carbon dioxide concentrations; and (5)

groundwater level fluctuations (drawdown). The induced vacuum responses are measured every ten to thirty minutes. The headspace combustible vapour, oxygen, and carbon dioxide concentrations are measured every thirty to sixty minutes. Drawdown is measured approximately every sixty minutes.

System parameters monitored are: (1) applied (well head) vacuum; (2) system vacuum; (3) vapour phase flow rate (air extraction rate); (4) groundwater extraction rates; (5) NAPL recovery rate; (6) effluent combustible vapour concentration; (7) effluent oxygen concentration; and (8) effluent carbon dioxide concentration. System performance data is recorded approximately every thirty to sixty minutes. Both system and monitoring point data should be recorded more frequently during the first hour of the test.

Extracted groundwater and vapour samples are collected during the pilot study in order to determine the following information: (1) potential groundwater treatment options; (2) potential groundwater discharge points; (3) vapour treatment options; and (4) contaminant mass removal rates (Cushman-Ball, 1999). NAPL recovery rates should be monitored every thirty minutes for the first two hours of the test, every two hours for the next ten hours, then every twelve hours until the test is complete. This procedure simplifies differentiation of the initial slug of NAPL recovered during the start of each test from sustainable NAPL recovery (Battelle, 1996).

In situ biorespiration tests may be conducted prior to and after the VER pilot study to determine the oxygen utilization rate. High oxygen utilization rates (e.g., >1%/day) are a good indication that bioslurper-mediated aeration would effectively improve microbial activity. If oxygen utilization rates are low, yet significant contamination is present, other

factors such as high clay content, low moisture content, nutrient limitation, and/or contaminant levels toxic to microorganisms may result in limiting biodegradation. Site-specific variables affecting microbial degradation should be identified to determine whether the conditions can be improved to implement enhanced bioremediation (Battelle, 1996). For a complete guide to conducting in situ biorespiration tests see Hincbee et. al. (1992).

Various methods of interpreting pilot study data to predict zones of influence are currently being utilized. The methods include: (1) graphical; (2) analytical; and (3) numerical.

The graphical method of evaluating groundwater level fluctuation data during a pilot study provides a simple and efficient means of predicting capture zones. This method consists of performing a linear regression analysis on the drawdown data collected from monitoring points during the pilot study. Specifically, linear regression is performed on a semi-logarithmic plot of the maximum drawdown observed at each monitoring point near the end of the pilot test versus the distance from the extraction well to the monitoring points. The point at which the regressed line intersects a drawdown of 0 metres (the x-axis) is considered the maximum radius of groundwater influence for the recovery well. Based on the results, an effective radius of groundwater influence can be inferred at a specific operating vacuum with an expected groundwater and vapour extraction rates.

The zone of vapour or vacuum influence can also be determined graphically. Similar to the graphical method for groundwater influence, the vacuum measured at the monitoring points is graphed versus the distance to the extraction well on a semi-log plot. A best-fit line is drawn through the points and the zone of influence is determined as the

distance at which a sufficient level of vacuum will be present to induce air flow. This “cut-off” vacuum level has been previously defined as 2.54 mm (0.1 inch) of water or 10% of the applied vacuum at the extraction well. This arbitrary cut-off vacuum level is an empirical value based on prior experience and geological conditions (Anderson, 1993).

The effects of a full scale VER system can be predicted simply by drawing circles with radii equal to the inferred zones of influence on a map of the site. An extraction well is placed at the centre of each of the circles. The number and locations of the extraction wells are determined when the circles on the map completely envelope the contamination plume. As a conservative measure, wells are placed such that adjacent zones of influence overlap each other.

The graphical method is a simple and practical means to predict zones of influence and, therefore, determine the number and placement of extraction wells in a conservative manner. However, the method is limited in that it does not consider the additive effects of several extraction wells operating simultaneously and does not allow for the manipulation of system operating parameters. That is, the effects of operating the system at different vacuums or extraction rates cannot be visualized. The limitations in the method may require that the engineer apply over conservative values resulting in excessive capital costs. On the other hand, the system may be under designed if the full scale system operates at a lower vacuum than the pilot system (for some unforeseen reason) and the effects of operating at a lower vacuum are not understood or considered.

The analytical method for predicting capture zones of VER systems employs traditional groundwater pumping calculations with some modifications to allow for the

dewatering of the soil in the vicinity of the extraction well and the negative pressure imparted on the subsurface.

In a conventional pump and treat situation in a low permeability formation, the Cooper-Jacob method can be applied to predict the discharge rate from an extraction well, but the observed drawdown must be corrected for dewatering first (Suthersan, 1997). The dewatering correction is as follows:

$$s_t = s_a - \frac{s_a^2}{2b} \quad (2.1)$$

where:

- s_t = theoretical drawdown corrected for dewatering, in metres
- s_a = actual drawdown, in metres
- b = aquifer thickness, in metres

This theoretical drawdown may be further modified, to include the effects of the negative pressure imparted on the subsurface, by:

$$s_v = s_t - P \quad (2.2)$$

where:

- s_v = drawdown corrected for vacuum on extraction well, in metres
- s_t = theoretical drawdown corrected for dewatering, in metres
- P = negative pressure imparted on the subsurface, in metres of water

The Cooper-Jacob equation then allows calculating the discharge using the following equation:

$$Q = \frac{s_v T}{264 \log\left(\frac{0.3Tr}{r^2 S}\right)} \quad (2.3)$$

where:

- Q = discharge, in gallons per minute (gpm)
 s_v = drawdown corrected for vacuum, in feet
 T = transmissivity, in gallons per day per foot (gpd/ft.) ($T=Kb$)
 t = pumping time, in days
 r = borehole radius, in feet
 S = storage coefficient

Standard capture zone equations can now be employed to calculate the distance to the stagnation point (χ_0), the capture width at the well (ω_0), and the upgradient capture width (ω) as follows (Suthersan, 1997):

$$\chi_0 = \frac{Q}{2\pi TI} \quad (2.4)$$

$$\omega_0 = \frac{Q}{2TI} \quad (2.5)$$

$$\omega = \frac{Q}{TI} \quad (2.6)$$

where:

I = hydraulic gradient in m/m

The analytical method typically results in an overestimated capture zone.

Consequently, a conservative and logical approach must be applied when employing this method. The example given above is only one of many potential analytical techniques for capture zone predictions. Other methods also incorporate modifications of traditional groundwater recovery calculations.

The numerical method for predicting capture zones is often onerous and costly. Numerical modeling can be performed using programs such as VISUAL MODFLOW and other well known groundwater/contaminant transport software packages. Most groundwater modeling programs, however, are not able to incorporate dewatering and vacuum and vacuum effects. More recent modeling programs such as BIOSLURP have been developed to incorporate multiphase flow and vacuum effects. Any numerical modeling effort will require an increased amount of site data and repetitive field calibration. The main advantage of the numerical method is the ability to model the effects of several full scale VER system options which would optimize system design. Therefore, the numerical method should only be employed at very large complex sites where projected remediation costs warrant the additional design cost.

3 CASE STUDY

The following case study presents the results of a VER pilot study and VER system design for an operating retail gasoline facility (Cushman-Ball, 1999).

3.1 Site Overview

The facility currently operates as a retail gasoline station and convenience store in the province of Alberta. Two grades of gasoline are stored in two separate fibreglass underground storage tanks (USTs) on the property. The USTs are located northeast of the store building and gasoline is dispensed from four dispensers located immediately north of the store building. A site plan is provided as Figure 1.

The store comprises the east end unit of a single story strip mall building with no basement. The property consists of an asphalt covered area to the east and north of the convenience store immediately adjacent to the building. Landscaped grass covered areas are located further to the north and east of the store building. The grounds are relatively flat. Surface drainage at the site appears to be directed towards the catch basins located on the parking lot and in the street. Regional surface drainage appears to be mainly to the northeast towards a creek located approximately one kilometre northeast of the subject property.

The building is municipally serviced with water, storm and sanitary sewerage systems, electricity and natural gas. The subject property occupies a total area of approximately 2,200 square metres and is located on the southwest corner of an intersection. The property is situated in a commercial and residential area. The property is

bounded to the north by a busy highway followed by a strip plaza; to the east by a small road followed by commercial properties; to the south by a laneway followed by residential properties; and to the west by commercial properties.

Based on previous environmental site investigations, the geology at the site comprised of approximately 0 to 2 feet of fill, followed by 2 to 4 feet of fine-grained sand with some clay, followed by stiff, fractured clay with some silt which extends to a depth of 25 feet below ground surface (bgs). Medium grained, wet sand was observed at 24 to 26 feet bgs in some boreholes.

The water table was located approximately 5 to 6 metres below ground surface (mbgs). Based on the groundwater elevations in the monitoring wells, groundwater beneath the site appeared to flow to the northeast. Based on the observed geology, the hydraulic conductivity of the soil appears to be between 10^{-2} to 10^{-5} cm/s.

In 1997, a UST systems leak test identified a potential breach in the premium gasoline piping. Consequently, environmental investigations were conducted to determine potential impacts to the subsurface. Extensive petroleum hydrocarbon contamination was identified at the site. Free phase NAPL was identified in several of the monitoring wells near the USTs. The NAPL appeared to be relatively fresh premium grade gasoline. The groundwater contamination consisted of typical petroleum constituents including benzene, toluene, ethylbenzene and xylenes (collectively termed BTEX), methyl tertiary-butyl ether (MTBE) and total petroleum hydrocarbons (TPH) with compounds having five to fifteen carbon atoms. The dissolved phase plume extended laterally beneath the entire property and beyond the property boundary to the north, east and only slightly to the south. The

soil contamination appeared to be located primarily in the northeast corner of the property at a depth of 3.6 to 7.2 metres below ground surface. Isoconcentration contours (isopleths) for total petroleum hydrocarbons (TPH) are presented in Figure 2.

The risks associated with the petroleum hydrocarbon contamination appeared to be limited to potential vapour impacts to subsurface structures, including nearby residential basement and utility corridors, and third party real estate liabilities. No potable or industrial groundwater wells were identified within a 500-metre radius of the subject property.

In the summer of 1998, a bioslurping pilot study was conducted to evaluate the feasibility of VER technology to capture and remove subsurface petroleum contamination. A primary objective of the pilot study was to quantify the mass of contaminants that could be recovered as well as the extent of influence of a full scale system. The mass of contaminants recovered was determined by recording air and groundwater flow measurements and collecting vapour and groundwater samples for analysis of petroleum constituents during testing. The radius of influence was determined by measuring the vacuum response, headspace combustible vapour concentrations, headspace oxygen concentrations, and groundwater level fluctuations at select monitoring points at various radial distances from the extraction points.

The VER pilot study consisted of two separate tests. The first test involved extracting from a 50-mm diameter well and the second test involved extracting from a 100-mm diameter well. The two tests were conducted separately to compare the performance of extracting from a 50-mm well compared to a 100-mm well. The following sections

describe the pilot study activities and results.

3.2 Pilot Study Equipment

The pilot tests were conducted using a 7.5 horsepower, oil-sealed liquid ring vacuum pump (LRVP). A liquid/vapour separator was employed upstream of the vacuum pump to facilitate the measurement of the vapour phase and liquid phase flow rates separately. Extracted groundwater was contained in two, 1900-litre (500-gallon), plastic tanks and subsequently transported offsite to a licenced disposal facility. The pilot study system was powered by a 25,000-Watt diesel generator, capable of providing sufficient 230 Volt, 3 Phase power.

The VER system extracted vapour and groundwater from the extraction wells through a 25-mm diameter, PVC reinforced, clear hose. One end of the hose was attached to the inlet of the liquid/vapour separator and the other end was placed approximately 300mm to 450mm from the bottom of the extraction well. A 600-mm long polyvinyl chloride (PVC) pipe, with a compression fitting and a 6-mm dilution valve, was attached to the top of the extraction well. The hose was inserted into the well, through the 600-mm long PVC pipe, and the compression fitting was subsequently tightened to seal the well. The maximum well head vacuum was achieved by ensuring that a tight seal was applied on the extraction well. The 6-mm dilution valve allowed for ambient air to be drawn into the extraction well to assist in lifting the groundwater out of the well, if required.

Applied vacuum was monitored on a fixed vacuum gauge with a measuring range of 0 to 762 millimetres of mercury (mm Hg) located upstream of the vapour-liquid separator. The discharge stack of the pilot system, which was constructed of 50-mm

diameter PVC, was fitted with one 9.5-inch female quick connect port for effluent combustible vapour and oxygen concentration monitoring. Vapour phase flow rates were measured using a rotating vane anemometer at the outlet of the discharge stack. The anemometer provided air flow velocity data in units of meters per second (m/s) which were later used to calculate vapour flow rates in units of actual cubic metres per minute (am^3/min). The extracted groundwater volume was measured, in units of litres (L), by a digital flow totalizer located between the liquids transfer pump and the plastic holding tanks. The total volume was then used to calculate the extracted groundwater flow rate, in units of litres per minute (Lpm) for various time intervals.

Induced vacuum responses were measured with Magnehelic gauges capable of measuring from -25 to 25, or -254 to 254, millimetres of water ($\text{mm H}_2\text{O}$). Headspace combustible vapour and oxygen concentrations were measured with a model RKI Eagle portable gas detector. The RKI Eagle displayed the combustible vapour concentrations in units of parts per million volume (ppmv), or percent of the lower explosive limit (% LEL), and oxygen concentrations in units of percent by volume (%). The groundwater level fluctuations were measured with a Solinst Model 122 interface probe in units of meters.

The monitoring points consisted of previously installed monitoring wells. In order to facilitate the measurement of induced vacuum responses, and headspace combustible vapour and oxygen concentrations without removing the 50-mm well caps which normally cap the wells, the well caps were fitted with brass, female, quick connect fittings. The monitoring points used to measure drawdown were left open to the atmosphere throughout each test.

3.3 Extraction Well Construction

A monitoring well, designated as MW-8, was previously installed as part of a subsurface investigation at the subject property. The monitoring well was constructed of 50-mm diameter, Schedule 40, PVC, number 10-slot well screen with 50-mm diameter, Schedule 40, PVC riser pipe. The well was completed to a depth of 7.6 mbgs with riser pipe from 0 to 1.5 mbgs and screen from 1.5 to 7.6 mbgs. Clean graded sand was placed around the well screen up to 300mm above the top of the screen. A bentonite seal was placed above the sand pack, from 0.30 to 1.2 mbgs, and sufficiently hydrated to allow swelling. The remaining borehole annulus was sealed with concrete to the existing grade. The well was equipped with a lock-in cap and protective manhole cover completed flush with the existing grade.

A recovery well, designated as RW-2, was previously installed to facilitate the recovery of free product and contaminated groundwater. The recovery well was constructed of 100-mm diameter, Schedule 40, PVC, number 10-slot well screen with 100-mm diameter, Schedule 40, PVC riser pipe. The well was completed to a depth of 7.6 mbgs with riser pipe from 0 to 1.5 mbgs and screen from 1.5 to 7.6 mbgs. Clean graded sand was placed around the well screen up to 600mm above the top of the screen. A bentonite seal was placed above the sand pack, from 0.3 to 1 mbgs, and sufficiently hydrated to allow swelling. The remaining borehole annulus was sealed with concrete to the existing grade. The well was equipped with a lock-in cap and protective manhole cover completed flush with the existing grade.

4 PILOT STUDY OBSERVATIONS

The pilot study comprised two distinct tests and utilized several of the existing monitoring wells at the site. During the first test, groundwater and soil vapours were extracted from MW-8 (a 50-mm diameter well). During the second test, groundwater and soil vapours were extracted from a 100-mm diameter well, RW-2. The locations of the monitoring wells are presented in Figure 2.

4.1 Test 1: Extraction from a 2-inch Diameter Well

Test 1 consisted of a 480-minute VER pilot test by extracting from monitoring well MW-8 of 50-mm diameter. All baseline data were recorded prior to starting the VER pilot system.

4.1.1 Pilot System Data

The pilot system was operated such that the maximum vacuum was applied to the extraction well throughout the test. The applied well head vacuum was measured at 533 mm Hg for the first 90 minutes of the test and decreased to 508 mm Hg for the remainder of the test. The extracted air flow rate ranged from approximately 0.53 to 0.68 am^3/min with an average of 0.62 am^3/min . The well head vacuum and extracted air flow rate data for Test 1 are presented graphically in Figure 3.

The extracted groundwater flow rate fluctuated throughout Test 1 ranging from a maximum of approximately 6.4 Lpm at the beginning of the test to a minimum of 1.4 Lpm at 90 minutes. An average extracted groundwater flow rate of 2.9 Lpm was calculated from the data obtained during Test 1. The extracted groundwater flow rate data for Test 1

are presented graphically in Figure 4.

Effluent combustible vapour and oxygen concentrations were measured at the sample port located on the discharge stack of the pilot system and are presented in Figure 5. The measured combustible vapour concentrations indicate that combustible vapours remained in excess of 11,000 ppmv (100% LEL) for the duration of Test 1. Due to the fact that the gas detector had a measuring limit of 100% LEL, fluctuations in combustible vapour concentrations could not be observed beyond this limit. The high effluent vapour concentrations and relatively high extracted air flow rate indicate that an adequate contaminant mass removal rate may be achieved with a VER system. Estimated mass removal rates are discussed in Section 5.0.

The effluent oxygen concentrations indicate that oxygen concentrations decreased from 9.1% at the beginning of Test 1 to 7.2% at 130 minutes into the test. The oxygen concentrations increased steadily from the 130-minute mark to 10.1% by the end of Test 1. Based on the increasing effluent oxygen concentrations, it appears that ambient air may have been entering the subsurface through grass covered areas located near the extraction well. The increased oxygen concentrations in the subsurface may enhance the biodegradation of petroleum contaminants in the soil and groundwater.

All pilot system data for Test 1 are presented in Table 1.

4.1.2 Monitoring Point Data

Induced vacuum, headspace combustible vapour concentrations and headspace oxygen concentrations were measured at the following seven monitoring points throughout the pilot test: MW-13, MW-20, MW-7, MW-18, MW-14, MW-17, and MW-11.

Groundwater level fluctuations (drawdown) were measured at the following six monitoring points throughout the pilot test: RW-2, RW-1, BH-1, BH-2, BH-3, and MW-15. The results are discussed in the following section.

The induced vacuum measurements in each monitoring point are presented graphically in Figure 6. These measurements indicate that there was no vacuum response observed at five of the seven monitoring points. The highest response was observed in monitoring point MW-20 (5 mm H₂O) located approximately 11.3m away from the extraction well. A vacuum response was also observed in monitoring point MW-13 (1.3 mm H₂O) located approximately 11m away from the extraction well.

The combustible vapour concentrations in each monitoring point are presented graphically in Figure 7. These measurements indicate that combustible vapours remained in excess of 11,000 ppmv (100% LEL) in monitoring points MW-13 and MW-18 for the duration of the pilot test. Due to the fact that the gas detector had a measuring limit of 100% LEL, fluctuations in combustible vapour concentrations could not be observed beyond this limit. Monitoring points which had baseline vapour concentrations below 100% LEL indicate that the combustible vapour concentrations fluctuated throughout Test 1. The combustible vapour concentration in MW-14 increased from 4,950 ppmv prior to the pilot test to greater than 11,000 ppmv (100% LEL) at 30 minutes into the test. Based on the headspace combustible vapour results, the 8-hour VER pilot test was not effective in reducing the vapour concentrations in the subsurface.

The headspace oxygen concentrations in each monitoring point are presented graphically in Figure 8. These measurements indicate that oxygen concentrations increased

slightly in monitoring points MW-20 (5%) and MW-7 (9%) and decreased in MW-13 (-20%), MW-18 (-6%), MW-14 (-45%), MW-17 (-25%) and MW-11 (-35%) throughout the course of the test. The decrease in oxygen concentrations may be attributed to a lack of sufficient ambient air recharge in the monitoring points.

All monitoring point data related to the induced vacuum, headspace combustible vapour concentrations and headspace oxygen concentrations are presented in Table 2.

The induced vacuum response data was graphed versus the distance from the extraction well to the monitoring points. The graph is presented in Figure 9. A linear regression analysis was not performed on this data due to a lack of correlation. The purpose of performing a regression analysis is to determine the appropriate spacing of additional extraction wells based on an estimated radius of vapour influence. Since regression data was not available, a conservative radius of vapour influence of 5.5 metres was estimated based on field observations and experience at similar sites.

The groundwater fluctuation data (drawdown) data for each monitoring point for Test 1 are presented graphically in Figure 10. The data indicates that a significant drawdown was observed at the monitoring points. The greatest drawdown was observed in monitoring point RW-1 (470mm) located approximately 4.2m away from the extraction well. The least drawdown was observed in monitoring point MW-15 (50mm) located approximately 25m away from the extraction well, near the centre of 4th Street N.E. All drawdown data obtained during Test 1 are presented in Table 3.

A linear regression analysis was performed on the drawdown data collected during Test 1 to determine the effective radius of groundwater influence for bioslurping from a

50-mm extraction well. Specifically, linear regression was performed on a semi-logarithmic plot of the maximum drawdown observed at each monitoring point at the end of the pilot test versus the distance from the extraction well to the monitoring points. The purpose for the analysis was to determine the appropriate spacing of additional extraction wells. The linear regression data is presented graphically in Figure 10.

From Figure 10, the point at which the regressed line intersects a drawdown of 0mm (the x-axis) is considered the maximum radius of groundwater influence for bioslurping. Based on the bioslurping pilot test results, the linear regression data, and experience at similar sites, an effective radius of groundwater influence of 27.4m for each 50-mm extraction well can be expected at an operating vacuum of 508 mm H₂O with an average extraction groundwater flow rate of approximately 2.91 Lpm.

4.2 Test 2: Extraction from a 100-mm Diameter Well

Test 2 consisted of a 280-minute VER pilot test by extracting from monitoring well RW-2 of 100-inch diameter. All baseline data were recorded prior to starting the VER pilot system.

4.2.1 Pilot System Data

The pilot system was operated such that the maximum vacuum was applied to the extraction well throughout the test. The applied well head vacuum was measured at 495 mm Hg at the beginning of the test and decreased steadily to 444 mm Hg by the end of the test. The extracted air flow rate ranged from approximately 0.91 to 1.10 am³/min with an average of 1.02 am³/min. The well head vacuum and extracted air flow rate data for Test 2 are presented graphically in Figure 11.

The extracted groundwater flow rate data for Test 2 are presented graphically in Figure 12. The extracted groundwater flow rate fluctuated throughout Test 2 with a minimum of 4.20 Lpm, observed at 180 minutes, and a maximum of 6.97 Lpm observed at the end of the test. The extracted groundwater flow rate decreased steadily from 6.06 Lpm to 4.20 Lpm for the initial 180 minutes of Test 2, at which point it began to rain heavily. Beyond 180 minutes, the extracted groundwater flow rate increased steadily to 6.97 Lpm. Overall the average extracted groundwater flow rate was calculated to be 5.75 Lpm.

Effluent combustible vapour and oxygen concentrations are presented graphically in Figure 13. Effluent combustible vapour and oxygen concentrations were measured at the sample port located on the discharge stack of the pilot system. The measured combustible vapour concentrations indicate that effluent combustible vapours remained in excess of 11,000 ppmv (100% LEL) for the duration of Test 2. The high effluent vapour concentrations and relatively high extracted air flow rate indicate that an adequate contaminant mass removal rate can be achieved with a VER system. Estimated mass removal rates are discussed in Section 6.0.

The effluent oxygen concentrations indicate that oxygen concentrations increased steadily from 6.5% at the beginning of the test to 12.3% by the end of the test. Based on the increasing effluent oxygen concentrations, it appears that ambient air may have been entering the subsurface through grass covered areas located near the extraction well. The increased oxygen concentrations in the subsurface may enhance the biodegradation of petroleum contaminants in the soil and groundwater.

All pilot system data for Test 2 are presented in Table 4.

4.2.2 Monitoring Point Data

Induced vacuum, headspace combustible vapour concentrations and headspace oxygen concentrations were measured at the following seven monitoring points throughout the pilot test: MW-8, MW-13, MW-20, MW-7, MW-18, MW-14, and MW-11.

Groundwater level fluctuations (drawdown) were measured at the following five monitoring points throughout the pilot test: RW-1, BH-1, BH-2, BH-3, and MW-15. The results are discussed in the following sections.

The induced vacuum measurements in each monitoring point are presented graphically in Figure 14. The induced vacuum measurements indicate that there was no vacuum response observed at five of the seven monitoring points. The highest response was observed in monitoring point MW-8 (11.4 mm H₂O) located approximately 4m away from the extraction well. A vacuum response was also observed in monitoring point MW-20 (1.3 mm H₂O) located approximately 14.6m away from the extraction well.

The measured headspace combustible vapour concentrations indicate that combustible vapours remained in excess of 11,000 ppmv (100% LEL) in monitoring points MW-13 and MW-18 for the duration of the pilot test. Monitoring points which had baseline vapour concentrations below 100% LEL indicate that the combustible vapour concentrations generally increased in the monitoring points throughout Test 2. The combustible vapour concentration in MW-8 increased from 5,500 ppmv prior to the pilot test to greater than 11,000 ppmv (100% LEL) by the end of the test. Based the headspace combustible vapour results, the 280-minute VER pilot test was not effective in reducing

the vapour concentrations in the subsurface.

The headspace oxygen concentrations in each monitoring point are presented graphically in Figure 16. The oxygen concentrations decreased in all the monitoring points throughout the course of Test 2. The greatest decrease in headspace oxygen concentration was observed in MW-11 (-70%). The decrease in oxygen concentrations may be attributable to a lack of sufficient ambient air recharge.

All monitoring point data for Test 2 related to the induced vacuum, headspace combustible vapour concentrations and headspace oxygen concentrations are presented in Table 5.

The induced vacuum response data was graphed versus the distance from the extraction well to the monitoring points. The graph is presented in Figure 17. A linear regression analysis was not performed on this data due to a lack of correlation. The purpose of performing a regression analysis is to determine the appropriate spacing of additional extraction wells based on an estimated radius of vapour influence. Since regression data was not available, a conservative radius of vapour influence of 13.7 metres was estimated based on field observations and experience at similar sites.

The groundwater fluctuation data (drawdown) indicate that a significant drawdown was observed at the monitoring points. The greatest drawdown was observed in monitoring point RW-1 (1,150mm) located approximately 3.5m away from the extraction well. The least drawdown was observed in monitoring point MW-15 (97mm) located approximately 22.1m away from the extraction well. The drawdown data for each monitoring point for Test 2 are presented graphically in Figure 18. All drawdown data

obtained during Test 2 are presented in Table 6.

A linear regression analysis was performed on the drawdown data collected during Test 2 to determine the effective radius of groundwater influence for VER from a 100-mm extraction well. Specifically, linear regression was performed on a semi-logarithmic plot of the maximum drawdown observed at each monitoring point at the end of the pilot test versus the distance from the extraction well to the monitoring points. The purpose for the analysis was to determine the appropriate spacing of additional extraction wells. The linear regression data are presented graphically in Figure 18.

From Figure 18, the point at which the regressed line intersects a drawdown of 0 feet (the x-axis) is considered the maximum radius of groundwater influence for VER. Based on the VER pilot test results, the linear regression data, and experience at similar sites, an effective radius of groundwater influence of 24.4m for each 100-mm extraction well can be expected at an operating vacuum of 444 mm Hg with an extraction groundwater flow rate of approximately 5.57 Lpm.

5 MASS REMOVAL ESTIMATES

Extracted groundwater and vapour samples were collected during the pilot study in order to determine the following information: (1) potential groundwater treatment options; (2) potential groundwater discharge points; (3) vapour treatment options (if required); and (4) contaminant mass removal rates.

The following paragraphs present the calculations and analytical results employed to estimate the mass removal rates for both the vapour and liquid phase effluent streams. Results from Test 1 and Test 2 are compared to determine whether a greater mass removal rate is achieved by extracting from a 50-mm or a 100-mm diameter extraction well.

5.1 Vapour Phase Mass Removal Rate

A grab sample of the extracted vapour was collected during extraction from MW-8 to estimate the mass removal rate of petroleum hydrocarbon contamination in the form of vapour. The vapour sample was collected while the VER pilot system was operating at a maximum flow rate of 0.68 m^3/min . The sample was collected in a 5-litre Tedlar bag from the sampling port located on the discharge stack of the pilot system. The sample in the Tedlar bag was then separately drawn across three pairs of carbon tubes using a calibrated SKC Aircheck personal sampling pump. Each pair of tubes was set up in series with the first tube downstream of the Tedlar bag designated as the front sample and the second tube as the back sample. The three pairs of tubes had a flow rate of approximately 156.1 mL/min (millilitres per minute) of sample drawn across them for periods of 3, 10 and 20 minutes, respectively. The ten minute sample, designated as VER-F10, VER-B10 was

submitted to Clayton Laboratory Services of Novi, Michigan. The carbon tube samples were analyzed for benzene, toluene, ethylbenzene, and xylenes (BTEX) using NIOSH Method 1501 and total petroleum hydrocarbons (TPH) using NIOSH Method 1550. The vapour analytical results for BTEX and TPH are summarized in Table 7.

The analytical results for the carbon tube samples are reported in units of mass, μg (micrograms). These mass units were calculated into mass concentrations, $\mu\text{g/L}$, (micrograms per litre) using the following equation:

$$C_v = \frac{M_v}{Q_s \times t} * 1000 \quad (5.1)$$

where:

C_v = Vapour phase concentration of the compound in $\mu\text{g/L}$

M_v = Vapour phase mass of the compound in μg determined by analysis of carbon tube sample

t = Sampling time in minutes

Q_s = Sample pump flow rate in mL/min. (156.1 mL/min.)

1000 = Conversion of mL to L

These concentrations were then converted into mass removal rates using:

$$\overline{M}_v = C_v \times Q_v \times 1.44 \times 10^{-3} \quad (5.2)$$

where:

\overline{M}_v = Vapour phase mass removal rate of the compound in kilograms per day

(kg/day)

Q_v = Extracted vapour flow rate in m^3/min

1.44×10^{-3} = Conversion to kg/day

Based on the vapour phase mass removal rates calculated using the analytical results and the equations given above, an initial vapour phase mass removal rate of 113 kg/day of total petroleum hydrocarbons is estimated per 50-mm extraction well and 179 kg/day per 100-mm extraction well. This rate is expected to decrease significantly as the remediation progresses. Calculated vapour phase concentrations are presented in Table 7.

5.2 Liquid Phase Mass Removal Rate

A grab sample of the extracted groundwater was collected during extraction from MW-8 to estimate the mass removal rate of petroleum hydrocarbon contamination in the form of liquid and to evaluate potential groundwater treatment alternatives. The sample was collected at 240 minutes into Test 1 from the discharge hose of the pilot system. The sample was placed in three 40-mL glass vials, five 1-L amber glass bottles, two 500-mL plastic jars, one 250-mL plastic jar, two 125-mL plastic jars, and two 100-mL glass bottles. The sample was stored on ice and shipped to Phillip Analytical Services Corporation of Mississauga, Ontario, for analysis of BTEX, trichloroethylene (TCE), methyl tert-butyl ether (MTBE), TPH, metals, mercury, phenols, biological oxygen demand (BOD), total suspended solids (TSS), pH, oil and grease, total oil and grease, nutrients, flashpoint, and microtoxicity. All samples were analyzed pursuant to the municipal sanitary sewer use bylaw. For the purposes of this report, only the analytical results for BTEX, MTBE and TPH are discussed. The analytical results for BTEX, MTBE and TPH are summarized in

Table 8.

The analytical results for the extracted groundwater samples were reported in units of concentration, $\mu\text{g/L}$. The concentration values and extracted groundwater flow rates were used to calculate the liquid phase mass removal rate by applying the following equation:

$$\overline{M}_l = C_l \times Q_l \times 1.44 \times 10^{-6} \quad (5.3)$$

where:

\overline{M}_l = Liquid phase mass removal rate of the compound, kg/day

C_l = Liquid phase concentration of the compound, $\mu\text{g/L}$

Q_l = Extracted groundwater flow rate, Lpm

1.44×10^{-6} = Conversion to kg/day

Based on the analytical results and the equation given above, an initial liquid phase mass removal rate of 0.07 kg/day is estimated per 50-mm extraction well and 0.15 kg/day per 100-mm extraction well. This rate is expected to decrease significantly as the remediation progresses.

5.3 Total Mass Removal Rate

The total (vapour phase and liquid phase) mass removal rates for Test 1 and Test 2 were estimated by performing a mass balance calculation for the vapour and liquid effluent streams. The mass balance was performed by adding the mass removal rates calculated for the vapour phase and liquid phase for each test.

Based on the mass balance calculations, a total mass removal rate of 113 lbs/day is estimated for each 50-mm extraction well and 179 kg/day for each 100-mm extraction

well. The total mass removal rate estimates indicate that approximately 99.9% of the contaminant mass removed is in the form of vapour. This is typical of bioslurping systems operating at gasoline contaminated sites due to the fact that a high degree of turbulence during the vacuum enhanced extraction process results in the volatilization of the petroleum hydrocarbons present in the groundwater. These mass removal rates, however, do not account for any enhanced biodegradation of the petroleum hydrocarbons caused by the VER system. The mass removal calculations are presented in Table 9.

6 CONCEPTUAL DESIGN OF VER SYSTEM

6.1 Design Summary

The proposed remediation system for this site was selected based on the ability of the technology to significantly reduce the concentrations of adsorbed phase, free phase, dissolved phase and vapour phase petroleum hydrocarbon contamination at the site. The effective clean-up duration and cost effectiveness of the proposed system have been taken into consideration.

The system will utilize eight extraction wells. Each well will be plumbed individually from manifolds located in the equipment building. The locations and number of extraction wells to be employed for the bioslurping system are determined by analysis of the pilot study data and consideration of the following objectives:

- The radii of influence for both the groundwater and soil vapour extraction must envelope the zone of contamination to a reasonable extent.
- Due to the heterogeneous geology of the contaminated area, additional extraction wells must be installed to address any petroleum constituents that may be trapped in fractures and intermittent sand layers.
- The system must be designed to maximize operating flexibility to optimize performance and minimize clean-up time.

A schematic of the VER system is presented in Figure 19. The locations of the extraction wells and the zones of groundwater and vapour influence are presented in Figure 20. The components of the system are summarized as follows:

Extraction System

- Eight extraction wells
- Vapour/liquid separator tank
- Oil-sealed liquid ring vacuum pump (LRVP)
- Transfer pumps and tanks
- Pressure, temperature, and flow controls and gauges

Water Treatment

- Oil/water separator tank
- Transfer pumps
- Low profile air stripper

Based on the pilot study results, an effective radius of vapour influence of 13.7m for each 100-mm diameter extraction well can be expected at an operating vacuum of 444 mm Hg with an air flow rate of 1.08 am³/min. Also, an effective radius of groundwater influence of 24.4m for each 100-mm diameter extraction well, completed to a depth of 7.6m bgs, can be expected at an extracted groundwater flow rate of 5.7 Lpm. The predicted areas of influence for vapour and groundwater are presented in Figure 20.

The proposed extraction system will be designed to process a minimum of 8.60 am³/min of soil vapour and a maximum of 57 Lpm of groundwater simultaneously from the eight extraction points at an operating vacuum of 457 mm Hg. A mixed stream of groundwater and soil vapour will be pumped into the vapour/liquid separator. Separated liquid will be pumped from the vapour/liquid separator tank to the oil/water separator tank. Product from the oil/water separator will be collected in a 205-litre drum as required.

The remaining water will be transferred to a low profile air stripper. The low profile air stripper will reduce the influent water petroleum hydrocarbon concentration by approximately 90%. The treated groundwater will be discharged to the site sanitary sewer pursuant to a Sewer Discharge Permit.

The vapours from the vapour/liquid separator will vent from the top of the unit and pass through the liquid ring vacuum pump and the vapour/oil separator tank. No vapour treatment for this type of system is required in the province of Alberta. In order to minimize any potential public health or safety concerns related to the discharge of petroleum vapours, the discharge rate will be manually controlled to reduce the emissions to an acceptable level. The discharge stack will be designed such that dispersion is maximized, and that the most likely point of impingement is furthest from the most sensitive receptor.

The vapour exhaust stream will be discharged through a 150-mm diameter stack extending approximately eight feet above the top of the system building. The stack will terminate beneath the convenience store roof to eliminate the potential for vapours to enter the store building through roof-mounted ventilation systems. The top of the discharge stack will have a ninety degree elbow in order to direct the vapour stream away from the residential area.

Although treatment of vapours is not required in this particular jurisdiction, it is required in most parts of the North America and, therefore, typically requires design consideration. Several options exist for treating vapour discharges for these types of remediation systems. Treatment options include thermal oxidation, catalytic oxidation,

carbon adsorption, biotreatment and reinjection. The type of vapour treatment system employed will depend on the mass or concentrations of contaminants being treated, the air flow volume and the discharge criteria.

6.2 Mass Removal Estimates

Based on the results of the VER pilot study, an initial vapour phase mass removal rate of 179 kg/day is estimated for each 100-mm extraction well and an initial liquid phase mass removal rate of 0.15 kg/day is estimated for each 100-mm extraction well. Therefore the total expected mass removal rate is expected to be 179.2 kg/day for each 100-mm extraction well. Given that the proposed system utilizes eight extraction wells, the total mass removal rate is expected to be approximately 1,430 kg/day. This rate is expected to decrease significantly as the remediation progresses.

6.3 System Components

6.3.1 Recovery Wells

Groundwater and soil vapour will be extracted from eight recovery wells designated as RW-1 through RW-8 at the proposed locations identified in Figure 20.

The proposed recovery wells will extend to a depth of approximately 7.6 mbgs. The screen interval will be from 3 to 7.6 mbgs, straddling the water table and extending throughout the zone of contamination in both the saturated and unsaturated zones. The recovery well screens will be constructed of 100-mm diameter, Schedule 40 PVC pipe machine slotted to 0.254mm. Clean graded sand will be placed around each well screen up to a minimum of 300mm above the top of the screen. A bentonite slurry will be placed above the sand pack to a depth of 1 mbgs to seal the borehole annulus. The remaining

borehole annulus will be filled with concrete to 0.6 mbgs. Each well will be equipped with a lock-in cap and a steel vault. Proposed extraction well details are presented in Figure 21.

6.3.2 Well Head Construction

The recovery wells will be secured inside a steel vault (0.6m by 0.6m by 0.6m). The steel vault will be installed 6mm above grade and secured by concrete. The concrete will be sloped towards the existing grade to prevent water accumulation near the extraction well. The steel vault will be traffic-bearing. Well head construction details are presented in Figure 21.

6.3.3 Liquid Ring Vacuum Pump

Pump performance curves were reviewed to determine the size of the liquid ring vacuum pump that would provide the required air flow rate at the estimated operating vacuum. The results of the review indicated that a 30-horsepower (hp) oil-sealed LRVP will be required to extract groundwater from the eight extraction wells. The 30-hp LRVP is capable of pumping both vapours and groundwater with an air flow capacity of approximately 10.75 am³/min at a vacuum of 457 mm Hg. Seal oil comes into direct contact with process fluid (groundwater and vapours). The seal oil is cooled in order to maintain proper operating conditions.

6.3.4 Vapour/Liquid Separator

Liquid and subsurface vapours will be extracted simultaneously from the recovery wells using the LRVP. The liquid stream will be tangentially separated from the vapour stream in the vapour/liquid separator. The separator vessel will be sized to provide adequate separation up to the maximum vapour/liquid flow rate developed by the LRVP.

The separator vessel will be of carbon steel construction with a removable head for internal inspection of the tank. A demisting pack will be installed on the vapour discharge port of the vessel, further enhancing its ability to remove entrained liquids from the vapour stream.

The vapour/liquid separator will be designed to remove 99.5% of droplets from the incoming vapour/liquid stream. The vessel will be equipped with a sight tube to observe the collection of liquids and ultrasonic level controls that allow the PLC to actuate a transfer pump for discharging of liquids to the water treatment module of the system.

6.3.5 Recovered Liquids Transfer Pump

Recovered liquids will be transferred from the vapour/liquid separator to the water treatment module by a 1.0 hp-explosion proof, progressive cavity pump. The pump will be chemically compatible with petroleum hydrocarbons and be able to transfer liquids from the vapour/liquid separator while the LRVP is in operation.

6.3.6 Oil/Water Separator

The oil/water separator will be designed to process up to 57 Lpm of liquids discharged from the vapour/liquid separator. This vessel will be designed to separate non emulsified hydrocarbon product from the liquid stream, with a separation efficiency of 99% for oil droplets greater than 40 microns in diameter. The vessel will be constructed of epoxy coated mild steel and will contain a PVC coalescing pack for suspended solids control and enhanced separation of free oil. Recovered product will be manually skimmed and collected in a 205-litre steel drum as required. Ultrasonic level switches will be installed in the oil/water collection chamber to allow control of the transfer pump and to warn of a high level alarm.

6.3.7 Low Profile Air Stripper

Effluent water will be pumped from the oil/water separator to a low profile air stripper by a 3/4-hp centrifugal pump. All transfer pumps utilized for the bioslurping system will be petroleum hydrocarbon compatible. The low profile air stripper will be designed to remove approximately 90% of the petroleum hydrocarbons in the extracted groundwater. The treatment efficiency of the air stripper is based on model runs conducted by the manufacturer. Model runs are conducted for an increasing number of air stripper "trays" until the desired efficiency is achieved or surpassed. Based in the results of the model runs, the air stripper will consist of three, stainless steel trays, a 1.5-hp explosion proof, regenerative blower to supply the stripping air, ultrasonic level switches to activate alarm situations, influent and effluent sample ports, a flow meter, a pressure gauge, a pressure sensor, and a sump site tube. A 3/4-hp centrifugal discharge pump will transfer the treated liquids to the sanitary sewer. The air stripper will be cleaned and maintained on a frequency suggested by the supplier to enhance performance and extend useful life.

6.3.8 System Protection

The bioslurping system will be constructed inside an 3m by 4.6m by 2.4m high building. The building will be a pre-engineered unit brought to the site pre-assembled and then mounted on a 4.4m by 5.9m concrete pad. The building will be wired with at least one explosion-proof 110V light and will include an explosion-proof exhaust fan and a fresh air vent. The building will also be insulated and will include an explosion proof heater. Since the LRVP will be located inside the building the atmosphere inside the building will be classified as Class I, Division 1 according to the Canadian Standards Association

(CSA). Explosion proof motors will be utilized inside the equipment building. A non-explosion proof control panel and breaker will be mounted on the outside of the equipment building.

6.3.9 System Controls

The bioslurping system will be controlled by a programmable logic controller (PLC) and one main electric control panel. The PLC and electric control panel will be located in a nonhazardous area outside of the equipment building. A licensed electrical contractor will adhere to all applicable Federal, Provincial and local codes during the electrical installation. System controls are illustrated in Figure 19 and are summarized as follows:

- High-high level control switch in the vapour/liquid separator will shut down the system;
- High level control switch in the vapour/liquid separator will activate the recovered liquids transfer pump (TP-1);
- Low level control switch in the vapour/liquid separator will deactivate the recovered liquids transfer pump (TP-1);
- Low-low level control switch in the vapour/liquid separator will shut down the system;
- High-high temperature control switch in the seal oil recirculation line will shut down the system;
- High-high level control switch in the vapour/oil separator will shut down the system;
- Low level control switch in the vapour/oil separator will shut down the system;
- High-High level control switch in the oil/water separator will shut down the system;

- High level control switch in the oil/water separator will activate the liquids transfer pump (TP-2) to the air stripper;
- Low level control switch in the oil/water separator will deactivate the liquids transfer pump (TP-2) to the air stripper;
- High air pressure control sensor/switch on the stripper blower will shut down the bioslurping system;
- High-high level control switch in the air stripper sump will shut down the bioslurping system;
- High level control switch in the air stripper sump will activate the final discharge pump (TP-3);
- Low level control switch in the air stripper sump will deactivate the final discharge pump (TP-3);
- Low-low level control switch in the air stripper sump will shut down the bioslurping system;
- High/low temperature switch within the building will shut down the system.

Remote telemetry will be integrated into the remediation system to interface with the system instrumentation and motor controls. Telemetry will enable remote monitoring and control of various system components via an auto-dialer system. The auto-dialer will notify the operator during an alarm situation.

6.4 Mechanical and Electrical

6.4.1 Piping

All piping within the bioslurping system building will be Schedule 40 steel with

threaded or butt welded connections. Subsurface piping will be 50-mm or 25-mm diameter, Schedule 80 PVC with all connections thoroughly cemented to form air-tight seals. Petroleum-resistant, high vacuum, 1-inch diameter hose will extend from the end of the subsurface piping located in the extraction well vault to a depth of approximately 7.2 mbgs inside the extraction well. Above ground system piping, located within the compound, will be 50-mm diameter, Schedule 80 PVC. A 25-mm diameter, Schedule 80 PVC discharge pipe will carry treated groundwater to the Store #22106 sanitary sewer.

6.4.2 Fittings and Valves

Schedule 40 steel fittings, and steel and brass valves will be used within the system building. Schedule 40 and Schedule 80 PVC fittings will be used to connect well head assemblies, conduits, and all extraction piping outside of the system building.

6.4.3 Electrical

Electrical wiring within the system building will be CSA certified as Class I, Division 1, hazardous location installations and will be completed in accordance with the any applicable Federal, Provincial or local codes. Equipment installed in the treatment system building will be CSA and Underwriters Laboratories (UL) listed and approved. The VER system shall be inspected and certified by a Calgary Electric System inspector upon installation. Equipment located inside the building shall be NEMA 7 (Class I, Group A, B, C or D hazardous locations - indoor) approved. The control panel shall be mounted outside the building, in a nonhazardous location, and be NEMA 3 (outdoor - weatherproof) approved.

7 CONCLUSION

VER technology is a practical remediation alternative at sites that have been impacted by petroleum hydrocarbons. The technology simultaneously addresses all forms of petroleum contamination (free phase, adsorbed phase, dissolved phase, and vapour phase) and is applicable in low transmissivity formations where traditional pump and treat methods are ineffective. Since there are limitations to VER technology, a thorough understanding of the site and a well planned and properly conducted pilot study are required to determine the efficiency of the technology and optimize system design.

Based on the literature review, VER is a relatively new subject in the field of remediation engineering. The earliest references date back to 1986 with the majority of the references dated more recent than 1992. This indicates that this is a relatively new field and additional research is required. Specific areas of research should focus on methods to limit the uncertainty in design due to site-specific heterogeneities, less onerous methods of applying numerical modeling to simulate multi-phase flow in the subsurface, and additional case studies to improve pilot study protocol and VER system design.

A case study is presented discussing pilot study activities and results. The results of the pilot study were subsequently employed to design a full scale VER system. Although the performance of the VER system is not discussed herein, it should be noted that specific protocols do exist for monitoring the system over time to ensure that the clean-up objectives are being met and that the predictions of the pilot study are being validated. System performance monitoring is also an area where additional research is required.

In conclusion, VER technology is being applied at more contaminated sites in North America everyday. Although the technology is based on a relatively simple premise, it has facilitated the remediation of contaminated sites that may have otherwise been too costly or technically impractical to clean up. As additional research is conducted, environmental engineers will attain the knowledge to design more efficient and cost effective systems. Eventually, continued research and development in the fields of remediation and prevention will provide the public with a cleaner, safer environment.

8 REFERENCES

- Anderson, William C., Ed., *Vacuum Vapour Extraction: Innovative Site Remediation Technology Series*, Vol. 8, American Academy of Environmental Engineers, Annapolis, MD, 1993.
- Ayyaswami, A. 1994. "Vacuum Enhanced Recovery: Theory and Applications." In: *Proceedings of Georgia Water Pollution Control Association*, Atlanta, Georgia.
- Barnes, D.L. and D.B. McWhorter. 1995. "Mechanics of Vacuum Enhanced Recovery of Hydrocarbons." In R.E. Hinchee, J.A. Kittel, and H.J. Reisinger (Eds.), *Applied Bioremediation of Petroleum Hydrocarbons*, Battelle Press, Columbus, Ohio. pp. 361-370.
- Battelle. 1996. *Best Practices Manual for Bioslurping*. Prepared for Naval Facilities Engineering Service Center, Port Hueneme, California.
- Blake, S.B., and M.M. Gates. 1986. "Vacuum Enhanced Hydrocarbon Recovery: A Case Study." In: *Proceedings of the NWWA/API Conference on Petroleum Hydrocarbons and Organic Chemicals in Groundwater: Prevention, Detection and Restoration*. Water Well Journal Publishing Company, Dublin, Ohio. pp. 709-721.
- Blake, S.B., B. Hockman, and M. Martin. 1990. "Applications of Vacuum Dewatering Techniques to Hydrocarbon Remediation." In: *Proceedings of Petroleum Hydrocarbons and Organic Chemicals in Groundwater: Prevention, Detection, and Restoration*. Las Vegas, Nevada.
- Cushman-Ball Environmental Ltd. 1999. Remedial Action Plan (Confidential Report).
- Granskog, A.H., Brennan, D.M., and J.S. Huber. 1994. "The Benefits and Challenges of Vacuum-Enhanced Groundwater Recovery Versus Conventional Groundwater Pump-and-Treat." In: *Proceedings of Petroleum Hydrocarbons and Organic Chemicals in Groundwater: Prevention, Detection, and Restoration*. Houston, Texas
- Hansen, M.A., M.D. Flavin, and S.A. Fam. 1994. "Vapor Extraction/Vacuum Enhanced Groundwater Recovery: A High-Vacuum Approach." In: *Proceedings of the 49th Annual Industrial Waste Conference*, Purdue University, West Lafayette, Indiana.
- Hinchee, R.E., S.K. Ong, R.N. Miller, D.C. Downey, and R. Frandt. 1992. *Test Plan and Technical Protocol for a Filed Treatability Test for Bioventing*, Rev. 2. U.S. Air Force Center for Environmental Excellence. Brooks Air Force Base, Texas.
- Parker, J.C. 1996. "Evaluating the Effectiveness of Product Recovery, Bioventing, and

Bioslurping Systems.” *Environmental Systems and Technology Inc. News*, ES&T, Vol. 4, Winter 95, Blacksburg, Virginia, pp.4-6.

Powers, J.P. 1981. *Construction Dewatering*. Wiley and Sons, New York City, NY.

Reisinger, H.J., P. Hubbard, S.A. Mountain, and C.W. Brigham. 1993. “Integrated Site Remediation System Using High Vacuum Application to Address Ground-Water Extraction, Soil Venting and In Situ Biodegradation.” Paper presented at EPA Groundwater Remediation/Stabilization Conference, held in Atlanta, Georgia.

Sittler, S.P., M.A. Hansen, M.M. Gates. 1993. “Theory and Applications of High Vacuum Technology to Remediate Hydrocarbon Impacted Soils and Groundwater in Low Permeability Formations (Including Case Histories).” In: *Proceedings of Petroleum Hydrocarbons and Organic Chemicals in Groundwater: Prevention, Detection, and Restoration*. Houston, Texas.

Suthersan, S.S. 1997. *Remediation Engineering Design Concepts*. Lewis Publishers, Boca Raton, Florida.

VITA AUCTORIS

Name: Marco Nardone

Place of Birth: Windsor, Ontario, Canada

Date of Birth: January 1, 1974

Education:

Master's of Applied Science
Environmental Engineering
University of Windsor
Windsor, Ontario, Canada
1997 - 2000

Bachelor's of Applied Science
Environmental Engineering
University of Windsor
Windsor, Ontario, Canada
1992 - 1996

Work/Experience:

Cushman-Ball Environmental Ltd.
Manager, Western Operations
Windsor, Ontario and Calgary, Alberta
1996 - 2000

Awards/Scholarships:

Professional Engineers Ontario Scholarship, 1995
Dean's Honour List, 1996
University of Windsor Entrance Scholarship, 1992

TABLES

Table 1
VER Pilot System Data
TEST 1
Extraction from Well MW-8 (50-mm diameter)

Time	Well Head Vacuum	System Vacuum	Extracted Air Velocity	Extracted Air Flow Rate	Extracted Groundwater Flow Rate	Effluent Combustible Vapour Concentration¹	Effluent Oxygen Concentration
(minutes)	(mm Hg)	(in. Hg)	(m/s)	(am³/min)	(Lpm)	(ppmv)	(Vol. %)
10	533	559	4.4	0.53	6.50	11,000	9.1
45	533	559	4.5	0.55	1.50	11,000	7.6
90	533	559	4.5	0.55	1.40	11,000	7.4
130	508	533	5.0	0.61	3.70	11,000	7.2
170	508	533	5.6	0.68	-	11,000	7.5
240	508	533	5.5	0.67	1.40	11,000	8.4
300	521	533	5.5	0.67	-	11,000	9.0
400	508	533	5.5	0.67	-	11,000	9.6
470	508	533	5.5	0.67	-	11,000	10.1
Minimum	508	533	4.4	0.53	1.40	11,000	7.2
Maximum	533	559	5.6	0.68	6.50	11,000	10.1
Average	518	542	5.1	0.62	2.90	11,000	8.4

Notes:

(1) Combustible vapour concentrations entered as 11,000 ppm (100% LEL) represent an exceedence of the gas detector measuring range. Although a value of 11,000 ppm was used for data interpretation purposes, the actual combustible vapour concentration exceeded 11,000 ppm.

- mm Hg - Millimetres of mercury vacuum
- ppmv - Parts per million by volume
- Lpm - Litres per minute
- am³/min - Actual cubic metres per minute
- m/s - Metres per second
- Vol. % - Percent by volume
- LEL - Lower explosive limit
- - Measurement not taken

Table 2
Monitoring Point Data
TEST 1
Extraction from Well MW-8 (50-mm diameter)

Time	Monitoring Point	Induced Vacuum	Headspace Combustible Vapour Concentration¹	Headspace Oxygen Concentration	Radial Distance
(minutes)		(mm H₂O)	(ppmv)	(Vol. %)	(metres)
0	MW-13	-	11.000	7.1	10.9
10	MW-13	0.00	-	-	10.9
20	MW-13	0.00	-	-	10.9
30	MW-13	-	11.000	8.1	10.9
50	MW-13	0.00	-	-	10.9
60	MW-13	-	11.000	8.6	10.9
100	MW-13	0.00	-	-	10.9
110	MW-13	-	11.000	8.1	10.9
140	MW-13	0.00	-	-	10.9
150	MW-13	-	11.000	7.3	10.9
180	MW-13	0.00	-	-	10.9
220	MW-13	-	11.000	6.7	10.9
240	MW-13	0.00	-	-	10.9
300	MW-13	0.00	-	-	10.9
310	MW-13	-	11.000	6.2	10.9
370	MW-13	-	11.000	5.8	10.9
380	MW-13	0.00	-	-	10.9
420	MW-13	1.30	-	-	10.9
440	MW-13	-	11.000	5.7	10.9
% Change			0%	-20%	
0	MW-20	-	35	19.9	11.3
10	MW-20	2.50	-	-	11.3
20	MW-20	2.50	-	-	11.3
30	MW-20	-	20	20.7	11.3
50	MW-20	3.80	-	-	11.3
60	MW-20	-	60	20.9	11.3
100	MW-20	3.80	-	-	11.3
110	MW-20	-	60	20.9	11.3
140	MW-20	3.80	-	-	11.3
150	MW-20	-	15	20.9	11.3
180	MW-20	3.80	-	-	11.3
220	MW-20	-	30	20.9	11.3
240	MW-20	3.80	-	-	11.3
300	MW-20	5.10	-	-	11.3
310	MW-20	-	0	20.9	11.3
370	MW-20	-	0	20.1	11.3
380	MW-20	5.10	-	-	11.3
420	MW-20	5.10	-	-	11.3
440	MW-20	-	5	20.9	11.3
% Change			-86%	5%	

Continued...

Table 2 (Continued)

**Monitoring Point Data
TEST 1
Extraction from Well MW-8 (50-mm diameter)**

Time	Monitoring Point	Induced Vacuum	Headspace Combustible Vapour Concentration¹	Headspace Oxygen Concentration	Radial Distance
(minutes)		(mm H₂O)	(ppmv)	(Vol. %)	(metres)
0	MW-7	-	490	17.4	12.9
10	MW-7	0.00	-	-	12.9
20	MW-7	0.00	-	-	12.9
30	MW-7	-	660	15.5	12.9
50	MW-7	0.00	-	-	12.9
60	MW-7	-	550	17.3	12.9
100	MW-7	0.00	-	-	12.9
110	MW-7	-	500	17.6	12.9
140	MW-7	0.00	-	-	12.9
150	MW-7	-	550	18.0	12.9
180	MW-7	0.00	-	-	12.9
220	MW-7	-	550	18.0	12.9
240	MW-7	0.00	-	-	12.9
300	MW-7	0.00	-	-	12.9
310	MW-7	-	460	18.4	12.9
370	MW-7	-	420	18.6	12.9
380	MW-7	0.00	-	-	12.9
420	MW-7	0.00	-	-	12.9
440	MW-7	-	480	19.0	12.9
% Change			-2%	9%	
0	MW-18	-	11.000	17.7	17.5
10	MW-18	0.00	-	-	17.5
20	MW-18	0.00	-	-	17.5
30	MW-18	-	11.000	17.9	17.5
50	MW-18	0.00	-	-	17.5
60	MW-18	-	11.000	17.6	17.5
100	MW-18	0.00	-	-	17.5
110	MW-18	-	11.000	17.5	17.5
140	MW-18	0.00	-	-	17.5
150	MW-18	-	11.000	17.1	17.5
180	MW-18	0.00	-	-	17.5
220	MW-18	-	11.000	16.9	17.5
240	MW-18	0.00	-	-	17.5
300	MW-18	0.00	-	-	17.5
310	MW-18	-	11.000	16.8	17.5
370	MW-18	-	11.000	16.6	17.5
380	MW-18	0.00	-	-	17.5
420	MW-18	0.00	-	-	17.5
440	MW-18	-	11,000	16.7	17.5
% Change			0%	-6%	

Continued...

Table 2 (Continued)

**Monitoring Point Data
TEST 1
Extraction from Well MW-8 (50-mm diameter)**

Time	Monitoring Point	Induced Vacuum	Headspace Combustible Vapour Concentration¹	Headspace Oxygen Concentration	Radial Distance
(minutes)		(mm H₂O)	(ppmv)	(Vol. %)	(metres)
0	MW-14	-	4,950	13.0	24.1
10	MW-14	0.00	-	-	24.1
20	MW-14	0.00	-	-	24.1
30	MW-14	-	11,000	7.9	24.1
50	MW-14	0.00	-	-	24.1
60	MW-14	-	11,000	7.8	24.1
100	MW-14	0.00	-	-	24.1
110	MW-14	-	11,000	7.7	24.1
140	MW-14	0.00	-	-	24.1
150	MW-14	-	11,000	7.6	24.1
180	MW-14	0.00	-	-	24.1
220	MW-14	-	11,000	7.3	24.1
240	MW-14	0.00	-	-	24.1
300	MW-14	0.00	-	-	24.1
310	MW-14	-	11,000	7.1	24.1
370	MW-14	-	11,000	7.1	24.1
380	MW-14	0.00	-	-	24.1
420	MW-14	0.00	-	-	24.1
440	MW-14	-	11,000	7.2	24.1
% Change			122%	-45%	
0	MW-17	-	260	15.1	30.2
10	MW-17	0.00	-	-	30.2
20	MW-17	0.00	-	-	30.2
30	MW-17	-	430	13.4	30.2
50	MW-17	0.00	-	-	30.2
60	MW-17	-	390	13.1	30.2
100	MW-17	0.00	-	-	30.2
110	MW-17	-	280	12.8	30.2
140	MW-17	0.00	-	-	30.2
150	MW-17	-	460	12.2	30.2
180	MW-17	0.00	-	-	30.2
220	MW-17	-	490	11.8	30.2
240	MW-17	0.00	-	-	30.2
300	MW-17	0.00	-	-	30.2
310	MW-17	-	520	11.4	30.2
370	MW-17	-	510	11.4	30.2
380	MW-17	0.00	-	-	30.2
420	MW-17	0.00	-	-	30.2
440	MW-17	-	550	11.3	30.2
% Change			112%	-25%	

Continued...

Table 2 (Continued)

**Monitoring Point Data
TEST 1
Extraction from Well MW-8 (50-mm diameter)**

Time	Monitoring Point	Induced Vacuum	Headspace Combustible Vapour Concentration¹	Headspace Oxygen Concentration	Radial Distance
(minutes)		(mm H₂O)	(ppmv)	(Vol. %)	(metres)
0	MW-11	-	4.180	5.4	31.9
10	MW-11	0.00	-	-	31.9
20	MW-11	0.00	-	-	31.9
30	MW-11	-	1.540	8.2	31.9
50	MW-11	0.00	-	-	31.9
60	MW-11	-	1.430	7.6	31.9
100	MW-11	0.00	-	-	31.9
110	MW-11	-	1.870	6.8	31.9
140	MW-11	0.00	-	-	31.9
150	MW-11	-	2.640	6.1	31.9
180	MW-11	0.00	-	-	31.9
220	MW-11	-	2.970	5.4	31.9
240	MW-11	0.00	-	-	31.9
300	MW-11	0.00	-	-	31.9
310	MW-11	-	3.850	4.2	31.9
370	MW-11	-	3.850	4.1	31.9
380	MW-11	0.00	-	-	31.9
420	MW-11	0.00	-	-	31.9
440	MW-11	-	4.180	3.5	31.9
% Change			0%	-35%	

Notes:

(1) Combustible vapour concentrations entered as 11,000 ppm (100% LEL) represent an exceedence of the gas detector measuring range. Although a value of 11,000 ppm was used for data interpretation purposes, the actual combustible vapour concentration exceeded 11,000 ppm.

mm H₂O - Millimetres of water
 ppmv - Parts per million by volume
 LEL - Lower explosive limit
 Vol. % - Percent by volume
 - - Measurement not taken

Table 3
Water Level Data
TEST 1
Extraction from Well MW-8 (50-inch diameter)

Time	Monitoring Point	Depth to Water	Drawdown	Radial Distance
(minutes)		(metres)	(metres)	(metres)
0	RW-2	4.41	0.00	4.0
40	RW-2	4.49	0.08	4.0
70	RW-2	4.56	0.15	4.0
120	RW-2	4.62	0.21	4.0
160	RW-2	4.67	0.26	4.0
230	RW-2	4.72	0.31	4.0
325	RW-2	4.80	0.39	4.0
390	RW-2	4.84	0.43	4.0
460	RW-2	4.87	0.46	4.0
% Change		10.5%		
0	RW-1	4.52	0.00	4.3
40	RW-1	4.65	0.13	4.3
70	RW-1	4.73	0.21	4.3
120	RW-1	4.78	0.26	4.3
160	RW-1	4.82	0.30	4.3
230	RW-1	4.87	0.35	4.3
325	RW-1	4.93	0.41	4.3
390	RW-1	4.96	0.44	4.3
460	RW-1	4.99	0.47	4.3
% Change		10.4%		
0	BH-1	4.47	0.00	6.9
40	BH-1	4.58	0.11	6.9
70	BH-1	4.64	0.16	6.9
120	BH-1	4.68	0.21	6.9
160	BH-1	4.72	0.25	6.9
230	BH-1	4.76	0.29	6.9
325	BH-1	4.82	0.35	6.9
390	BH-1	4.85	0.38	6.9
460	BH-1	4.88	0.41	6.9
% Change		9.1%		
0	BH-2	4.52	0.00	14.4
40	BH-2	4.55	0.03	14.4
70	BH-2	4.58	0.06	14.4
120	BH-2	4.60	0.08	14.4
160	BH-2	4.62	0.11	14.4
230	BH-2	4.65	0.14	14.4
325	BH-2	4.69	0.17	14.4
390	BH-2	4.71	0.19	14.4
460	BH-2	4.73	0.21	14.4
% Change		4.7%		

Continued...

Table 3 (Continued)**Water Level Data
TEST 1
Extraction from Well MW-8 (50-inch diameter)**

Time	Monitoring Point	Depth to Water	Drawdown	Radial Distance
(minutes)		(metres)	(metres)	(metres)
0	BH-3	4.12	0.00	16.9
40	BH-3	4.13	0.02	16.9
70	BH-3	4.14	0.02	16.9
120	BH-3	4.15	0.03	16.9
160	BH-3	4.15	0.04	16.9
230	BH-3	4.16	0.05	16.9
325	BH-3	4.17	0.06	16.9
390	BH-3	4.18	0.07	16.9
460	BH-3	4.19	0.08	16.9
% Change		1.8%		
0	MW-15	3.77	0.00	25.0
40	MW-15	3.78	0.01	25.0
70	MW-15	3.79	0.01	25.0
120	MW-15	3.79	0.02	25.0
160	MW-15	3.79	0.02	25.0
230	MW-15	3.80	0.03	25.0
325	MW-15	3.81	0.03	25.0
390	MW-15	3.81	0.04	25.0
460	MW-15	3.82	0.05	25.0
% Change		1.3%		

Table 4

VER Pilot System Data

TEST 2

Extraction from Well RW-2 (100-mm diameter)

Time	Well Head Vacuum	System Vacuum	Extracted Air Velocity	Extracted Air Flow Rate	Extracted Groundwater Flow Rate	Effluent Combustible Vapour Concentration'	Effluent Oxygen Concentration
(minutes)	(mm Hg)	(mm Hg)	(m/s)	(am³/min)	(Lpm)	(ppmv)	(Vol. %)
10	495	508	7.5	0.91		11,000	6.5
60	470	483	8.0	0.97	6.1	11,000	7.3
120	457	470	8.5	1.03	5.1	11,000	9.9
180	445	457	9.0	1.09	4.2	11,000	11.2
240	445	457	9.0	1.09	6.4	11,000	12.3
280	445	457	-	-	7.0	-	-
Minimum	445	457	7.5	0.91	4.2	11,000	6.5
Maximum	495	508	9.0	1.09	7.0	11,000	12.3
Average	460	472	8.4	1.02	5.8	11,000	7.9

Notes:

(1) Combustible vapour concentrations entered as 11,000 ppm (100% LEL) represent an exceedence of the gas detector measuring range. Although a value of 11,000 ppm was used for data interpretation purposes, the actual combustible vapour concentration exceeded 11,000 ppm.

- mm Hg - Millimetres of mercury vacuum
- ppmv - Parts per million by volume
- Lpm - Litres per minute
- am³/min - Actual cubic metres per minute
- m/s - Metres per second
- Vol. % - Percent by volume
- LEL - Lower explosive limit
- - Measurement not taken

Table 5
Monitoring Point Data
TEST 2
Extraction from Well RW-2 (100-mm diameter)

Time	Monitoring Point	Induced Vacuum	Headspace Combustible Vapour Concentration ^t	Headspace Oxygen Concentration	Radial Distance
(minutes)		(mm H ₂ O)	(ppmv)	(Vol. %)	(metres)
0	MW-8	—	5.500	19.9	4.0
10	MW-8	6.35	—	—	4.0
40	MW-8	8.89	4.400	19.1	4.0
90	MW-8	—	7.260	18.3	4.0
100	MW-8	8.89	—	—	4.0
180	MW-8	10.16	—	—	4.0
190	MW-8	—	10.890	16.9	4.0
250	MW-8	11.43	—	—	4.0
260	MW-8	—	11.000	16.0	4.0
290	MW-8	11.43	—	—	4.0
% Change			100%	-20%	
0	MW-13	—	11.000	5.0	8.9
10	MW-13	0.00	—	—	8.9
40	MW-13	0.00	11.000	5.1	8.9
90	MW-13	—	11.000	5.0	8.9
100	MW-13	0.00	—	—	8.9
180	MW-13	0.00	—	—	8.9
190	MW-13	—	11.000	4.9	8.9
250	MW-13	0.00	—	—	8.9
260	MW-13	—	11.000	4.9	8.9
290	MW-13	0.00	—	—	8.9
% Change			0%	-2%	
0	MW-20	—	550	13.4	14.6
10	MW-20	0.00	—	—	14.6
40	MW-20	0.00	880	12.7	14.6
90	MW-20	—	1,320	12.2	14.6
100	MW-20	0.00	—	—	14.6
180	MW-20	0.00	—	—	14.6
190	MW-20	—	1,540	11.3	14.6
250	MW-20	1.27	—	—	14.6
260	MW-20	—	2,200	11.0	14.6
290	MW-20	0.00	—	—	14.6
% Change			300%	-18%	

Continued...

Table 5 (Continued)

**Monitoring Point Data
TEST 2
Extraction from Well RW-2 (100-mm diameter)**

Time	Monitoring Point	Induced Vacuum	Headspace Combustible Vapour Concentration¹	Headspace Oxygen Concentration	Radial Distance
(minutes)		(mm H₂O)	(ppmv)	(Vol. %)	(metres)
0	MW-7	-	990	16.6	14.7
10	MW-7	0.00	-	-	14.7
40	MW-7	0.00	770	17.2	14.7
90	MW-7	-	880	17.2	14.7
100	MW-7	0.00	-	-	14.7
180	MW-7	0.00	-	-	14.7
190	MW-7	-	990	16.2	14.7
250	MW-7	0.00	-	-	14.7
260	MW-7	-	1,320	16.0	14.7
290	MW-7	0.00	-	-	14.7
% Change			33%	-4%	
0	MW-18	-	11,000	16.4	21.0
10	MW-18	0.00	-	-	21.0
40	MW-18	0.00	11,000	16.3	21.0
90	MW-18	-	11,000	16.3	21.0
100	MW-18	0.00	-	-	21.0
180	MW-18	0.00	-	-	21.0
190	MW-18	-	11,000	16.2	21.0
250	MW-18	0.00	-	-	21.0
260	MW-18	-	11,000	16.2	21.0
290	MW-18	0.00	-	-	21.0
% Change			0%	-1%	
0	MW-14	-	440	18.1	23.2
10	MW-14	0.00	-	-	23.2
40	MW-14	0.00	2,200	14.8	23.2
90	MW-14	-	3,960	13.7	23.2
100	MW-14	0.00	-	-	23.2
180	MW-14	0.00	-	-	23.2
190	MW-14	-	7,920	11.2	23.2
250	MW-14	0.00	-	-	23.2
260	MW-14	-	9,900	10.8	23.2
290	MW-14	0.00	-	-	23.2
% Change			2150%	-40%	

Continued...

Table 5 (Continued)

**Monitoring Point Data
TEST 2
Extraction from Well RW-2 (100-mm diameter)**

Time	Monitoring Point	Induced Vacuum	Headspace Combustible Vapour Concentration¹	Headspace Oxygen Concentration	Radial Distance
(minutes)		(mm H₂O)	(ppmv)	(Vol. %)	(metres)
0	MW-11	-	2,530	6.7	28.5
10	MW-11	0.00	-	-	28.5
40	MW-11	0.00	4,070	2.9	28.5
90	MW-11	-	4,070	3.0	28.5
100	MW-11	0.00	-	-	28.5
180	MW-11	0.00	-	-	28.5
190	MW-11	-	4,180	2.4	28.5
250	MW-11	0.00	-	-	28.5
260	MW-11	-	5,060	2.0	28.5
290	MW-11	0.00	-	-	28.5
% Change			100%	-70%	

Notes:

(1) Combustible vapour concentrations entered as 11,000 ppm (100% LEL) represent an exceedence of the gas detector measuring range. Although a value of 11,000 ppm was used for data interpretation purposes, the actual combustible vapour concentration exceeded 11,000 ppm.

- mm H₂O - Millimetres of water
- ppmv - Parts per million by volume
- LEL - Lower explosive limit
- Vol. % - Percent by volume
- - Measurement not taken

Table 6
Water Level Data
TEST 2
Extraction from Well RW-2 (100-mm diameter)

Time	Monitoring Point	Depth to Water	Drawdown	Radial Distance
(minutes)		(metres)	(metres)	(metres)
0	RW-1	4.63	0.00	3.50
50	RW-1	5.26	0.63	3.50
110	RW-1	5.67	1.04	3.50
200	RW-1	5.78	1.15	3.50
270	RW-1	5.77	1.14	3.50
% Change		24.56%		
0	BH-1	4.58	0.00	4.50
50	BH-1	5.37	0.80	4.50
110	BH-1	5.73	1.15	4.50
200	BH-1	5.83	1.25	4.50
270	BH-1	5.70	1.13	4.50
% Change		24.58%		
0	BH-2	4.59	0.00	11.80
50	BH-2	4.75	0.16	11.80
110	BH-2	4.93	0.34	11.80
200	BH-2	5.04	0.44	11.80
270	BH-2	5.06	0.47	11.80
% Change		10.28%		
0	BH-3	4.17	0.00	13.00
50	BH-3	4.30	0.14	13.00
110	BH-3	4.42	0.25	13.00
200	BH-3	4.47	0.31	13.00
270	BH-3	4.49	0.33	13.00
% Change		7.80%		
0	MW-15	3.84	0.00	22.10
50	MW-15	3.86	0.02	22.10
110	MW-15	3.90	0.06	22.10
200	MW-15	3.93	0.08	22.10
270	MW-15	3.94	0.10	22.10
% Change		2.52%		

Table 7

**VER Pilot Study
Summary of Extracted Vapour Analytical Results**

Sample	Parameter	Mass (µg) ¹	Sample Time (min.)	Sample Pump Flow Rate (mL/min.)	Concentration (µg/L) ²
VER-F10 ³	Benzene	1.100	10	156.10	705
	Toluene	3.600	10	156.10	2.306
	Ethylbenzene	53	10	156.10	34
	Xylenes	100	10	156.10	64
	TPH	160.000	10	156.10	102.498
VER-B10 ³	Benzene	< 2.0	10	156.10	NA
	Toluene	< 2.0	10	156.10	NA
	Ethylbenzene	< 2.0	10	156.10	NA
	Xylenes	< 2.0	10	156.10	NA
	TPH⁴	20.000	10	156.10	12.812
TOTAL TPH		180.000			115.311

Notes:

- (1) Vapour analytical results were presented in units of mass (micrograms)
- (2) Concentrations were calculated by applying Equation (7)
- (3) Carbon tube vapour samples were analyzed by NIOSH method 1501 for BTEX and 1550 for TPH
- (4) TPH detection on back carbon tube indicates that breakthrough of TPH occurred during sampling.

NA - Not applicable
 < - Less than
 µg - Micrograms
 min. - Minutes
 mL/min. - Millilitres per minutes
 µg/L - Micrograms per litre
 TPH - Total petroleum hydrocarbons

Table 8		
VER Pilot Study		
Summary of Extracted Groundwater Analytical Results		
Sample	Parameter	Concentration (µg/L)
VER-GW1	Benzene	1.310
	Toluene	1.420
	Ethylbenzene	732
	Xylenes	2.217
	MTBE	959
	TPH	15.900
	TEH	2.200
	Total Hydrocarbons¹	18.100
Notes:		
(1) Total hydrocarbons is the sum of TPH and TEH		
<	- Less than	
TPH	- Total purgeable hydrocarbons (carbon 6 to carbon 10 range)	
TEH	- Total extractable hydrocarbons (carbon 11 to carbon 32 range)	
µg/L	- Micrograms per litre	

Table 9
VER Pilot Study
Petroleum Hydrocarbon Mass Removal Estimates

Parameter	Vapour Phase					Liquid Phase					Maximum Total	
	Concentration (µg/L)	50-mm Extraction Well		100-mm Extraction Well		Concentration (µg/L)	50-mm Extraction Well		100-mm Extraction Well		50-mm	100-mm
		Pilot System Flow Rate (am ³ /min)	Mass Removal (kg/day) ¹	Pilot System Flow Rate (am ³ /min)	Mass Removal (kg/day) ¹		Pilot System Flow Rate (Lpm)	Mass Removal (kg/day)	Pilot System Flow Rate (Lpm)	Mass Removal (kg/day)	Mass Removal (kg/day)	Mass Removal (kg/day)
Benzene	705	0.68	0.7	1.08	1.1	1,310	2.9	0.0	5.8	0.0	0.7	1.1
Toluene	2,306	0.68	2.3	1.08	3.6	1,420	2.9	0.0	5.8	0.0	2.3	3.6
Ethylbenzene	34	0.68	0.0	1.08	0.1	732	2.9	0.0	5.8	0.0	0.0	0.1
Xylenes	64	0.68	0.1	1.08	0.1	2,217	2.9	0.0	5.8	0.0	0.1	0.1
TPH	115,311	0.68	112.8	1.08	178.6	18,100	2.9	0.1	5.8	0.2	112.9	178.7

Notes:

- (1) - Vapour phase mass removal rate was calculated by applying Equation (5.2)
- (2) - Liquid phase mass removal rate was calculated by applying Equation (5.3)

am³/min - Actual cubic metres per minute
kg/day - Kilograms per day
µg/L - Micrograms per litre
Lpm - Litres per minute
TPH - Total petroleum hydrocarbons
< - Less than

FIGURES

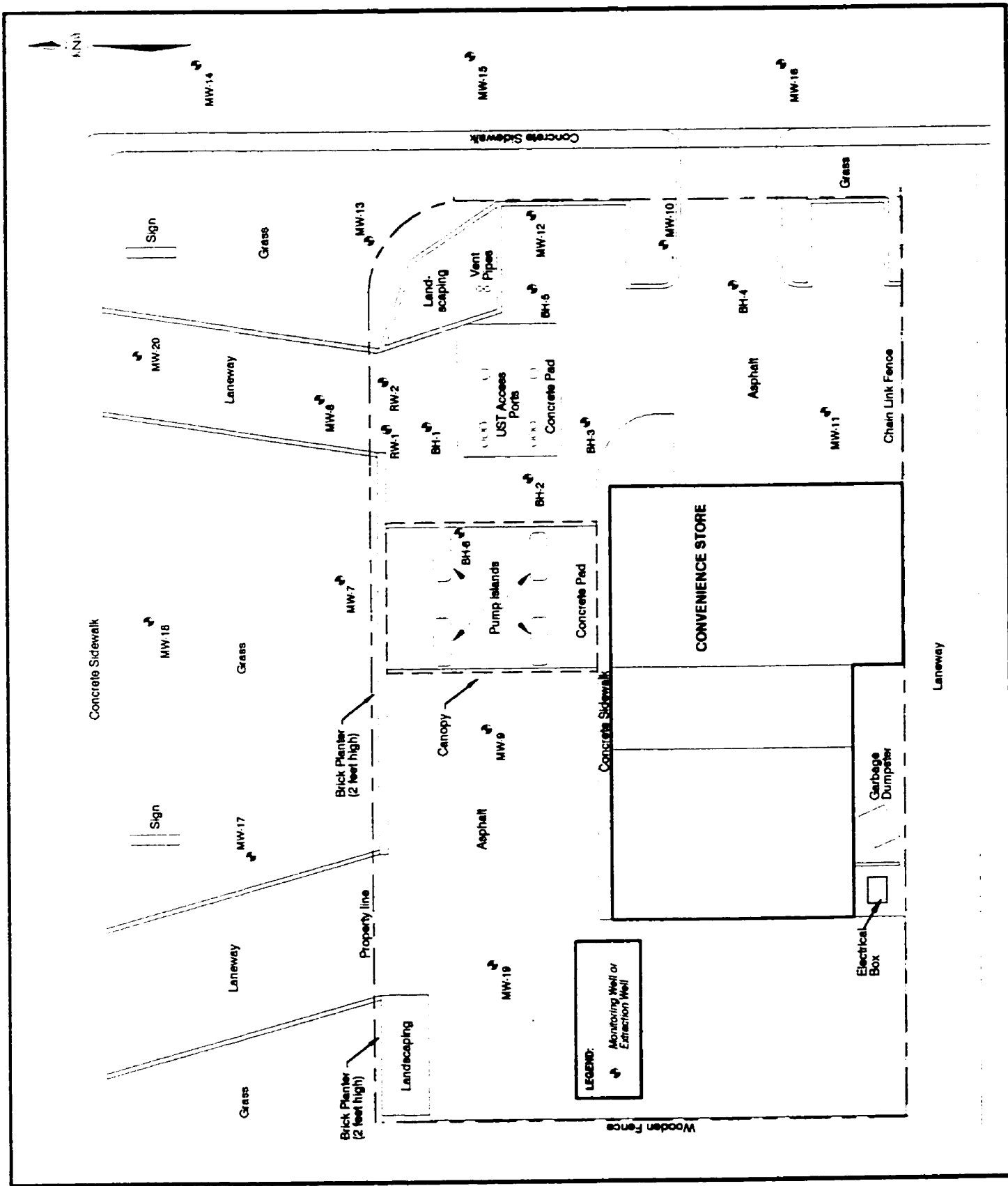

FIGURE 1. SITE PLAN SCALE: 1 : 350

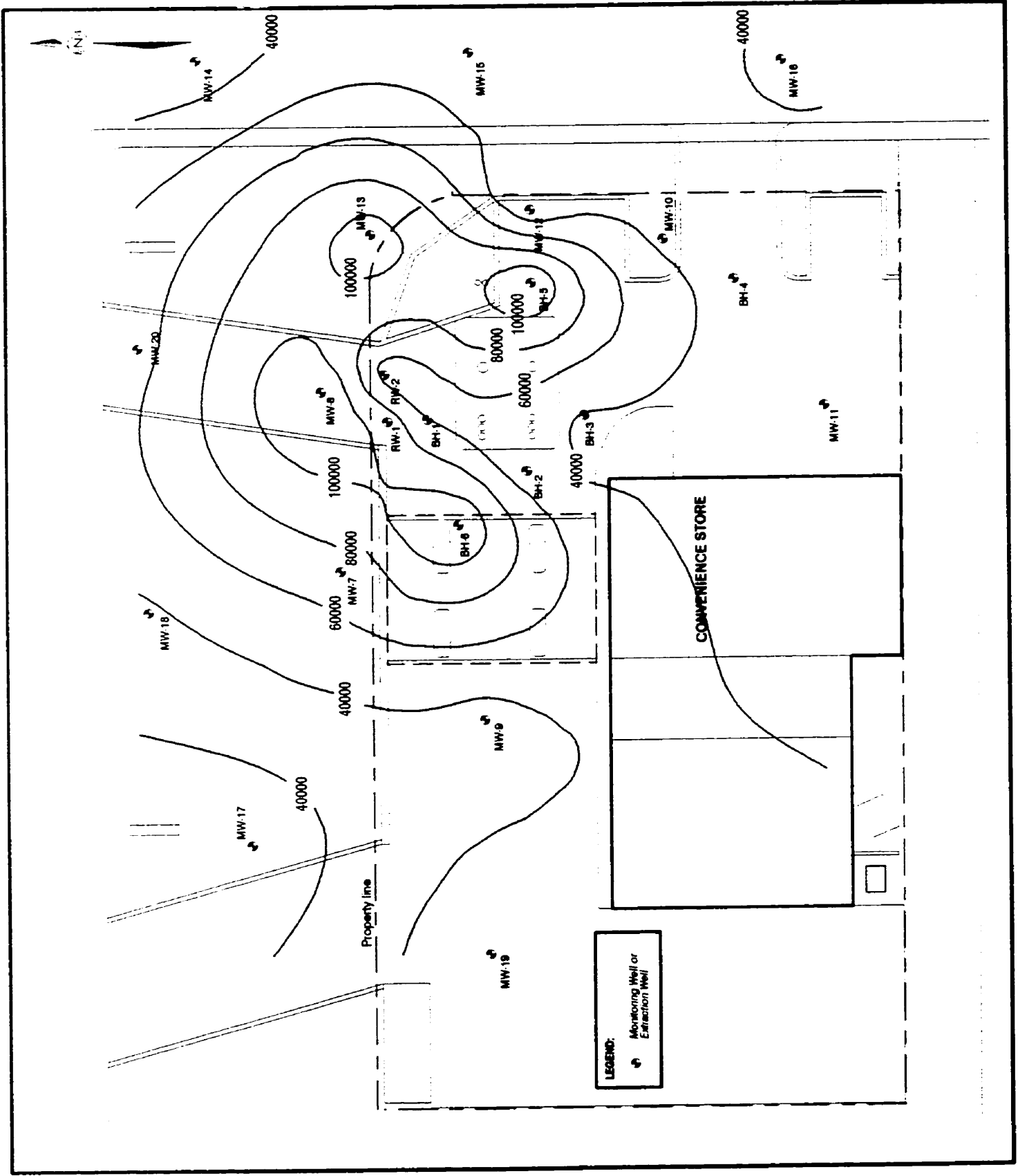

FIGURE 2. TPH ISOLPLETHS (ppb) SCALE: 1 : 350

Air Flow Rate and Vacuum vs. Time

Test 1

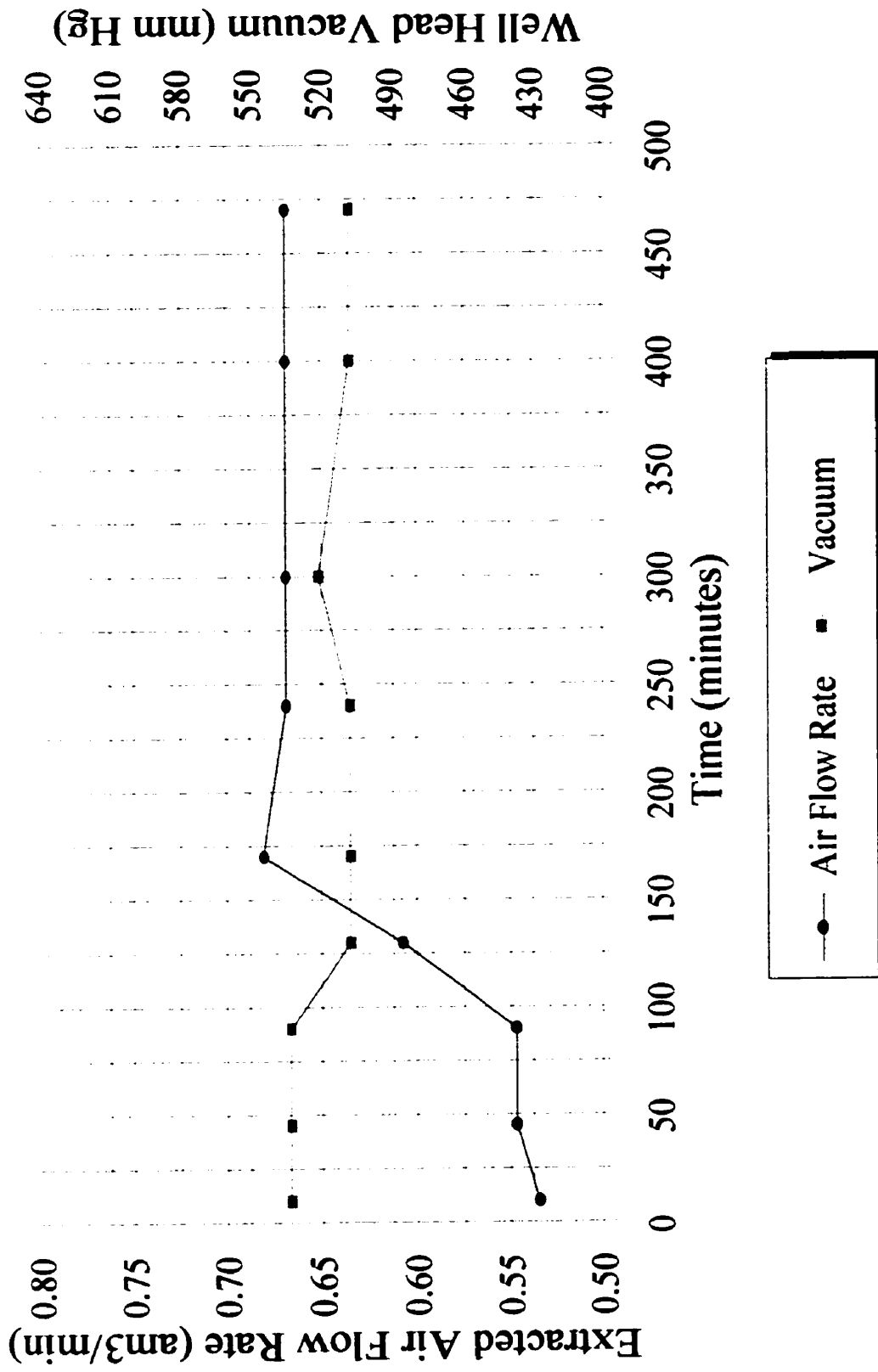

FIGURE 3

Groundwater Flow Rate vs. Time

Test 1

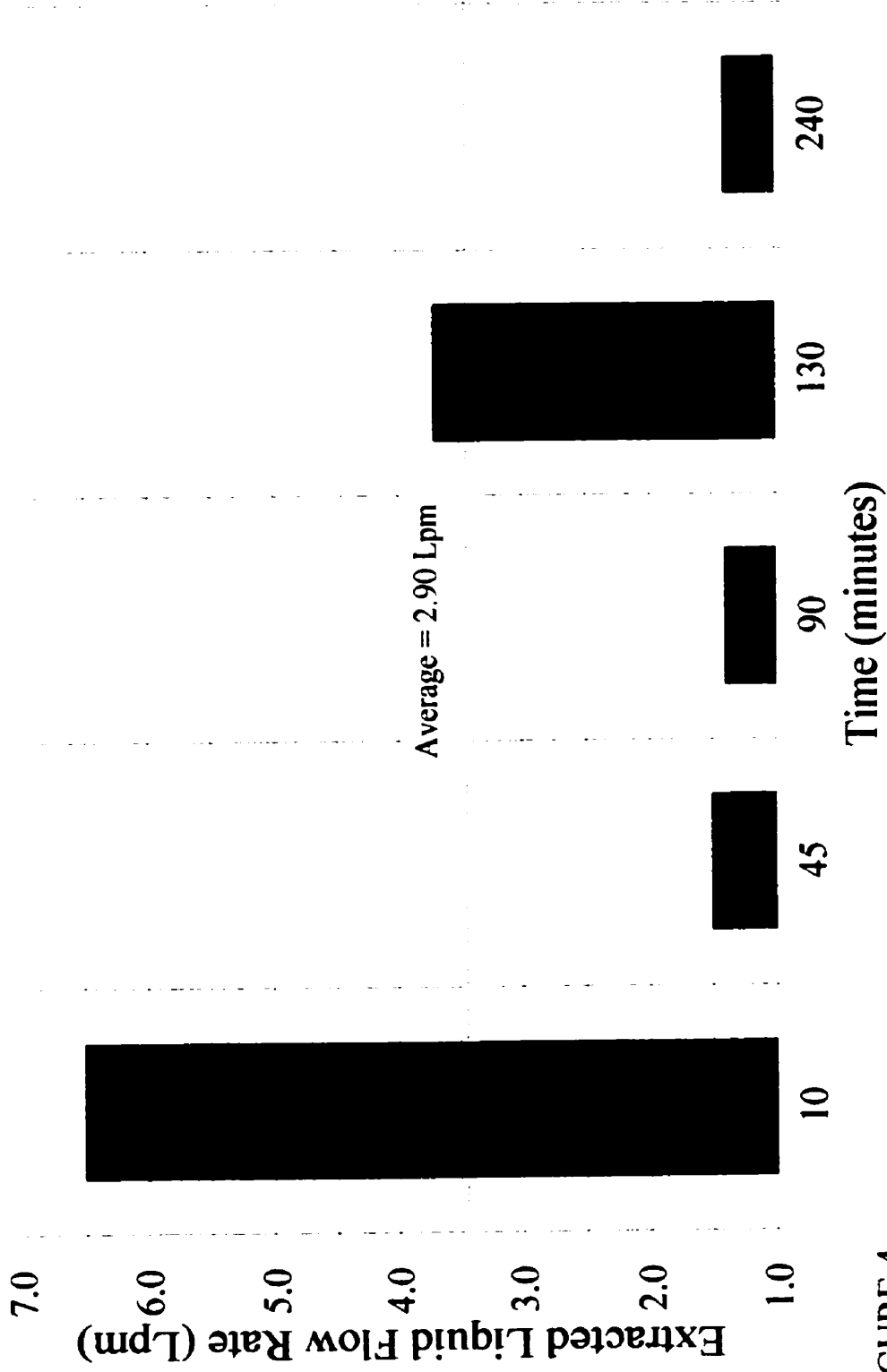

FIGURE 4

Oxygen and Vapour vs. Time

Test 1

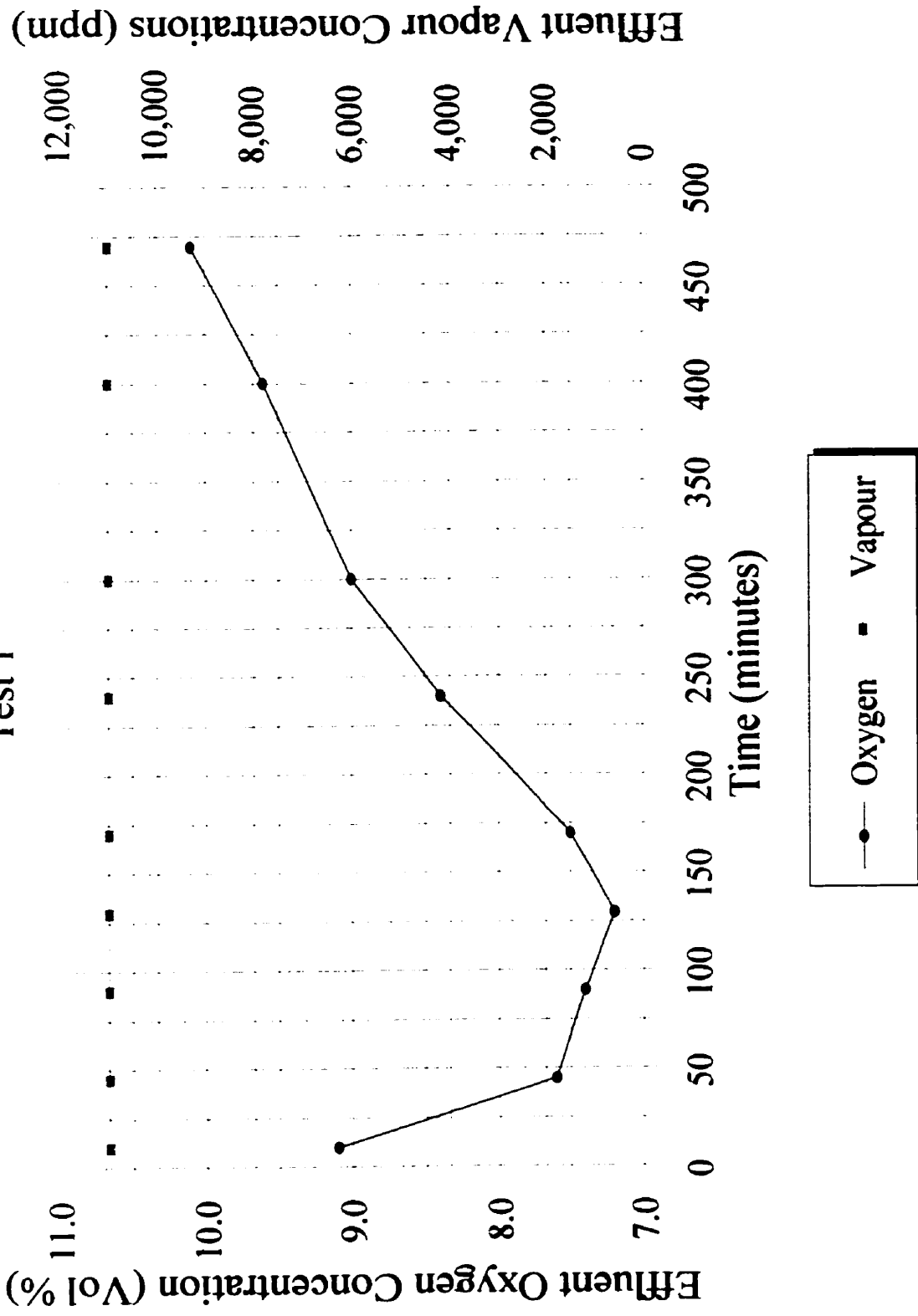

FIGURE 5

Induced Vacuum Test 1

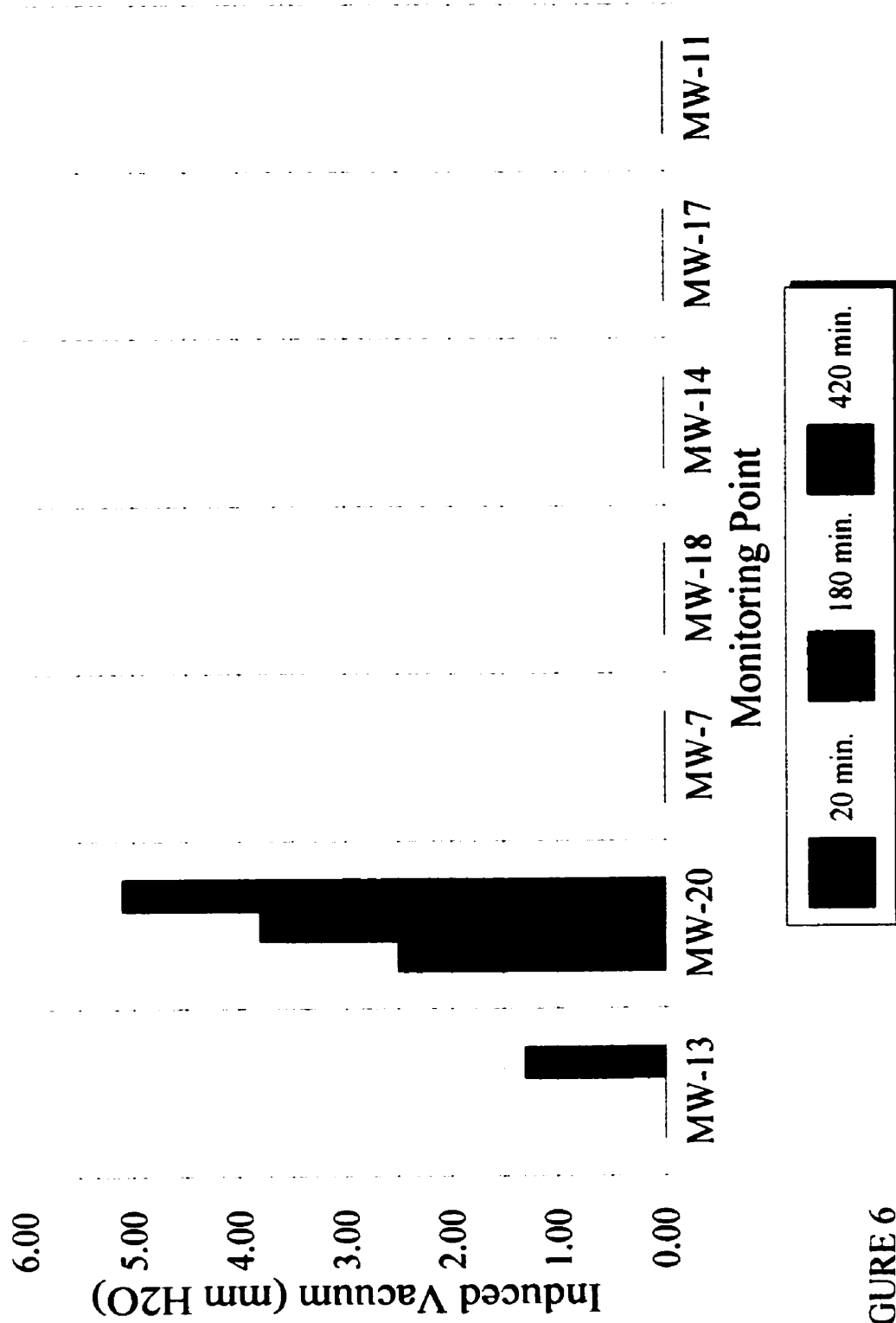

FIGURE 6

Headspace Vapour Concentrations

Test 1

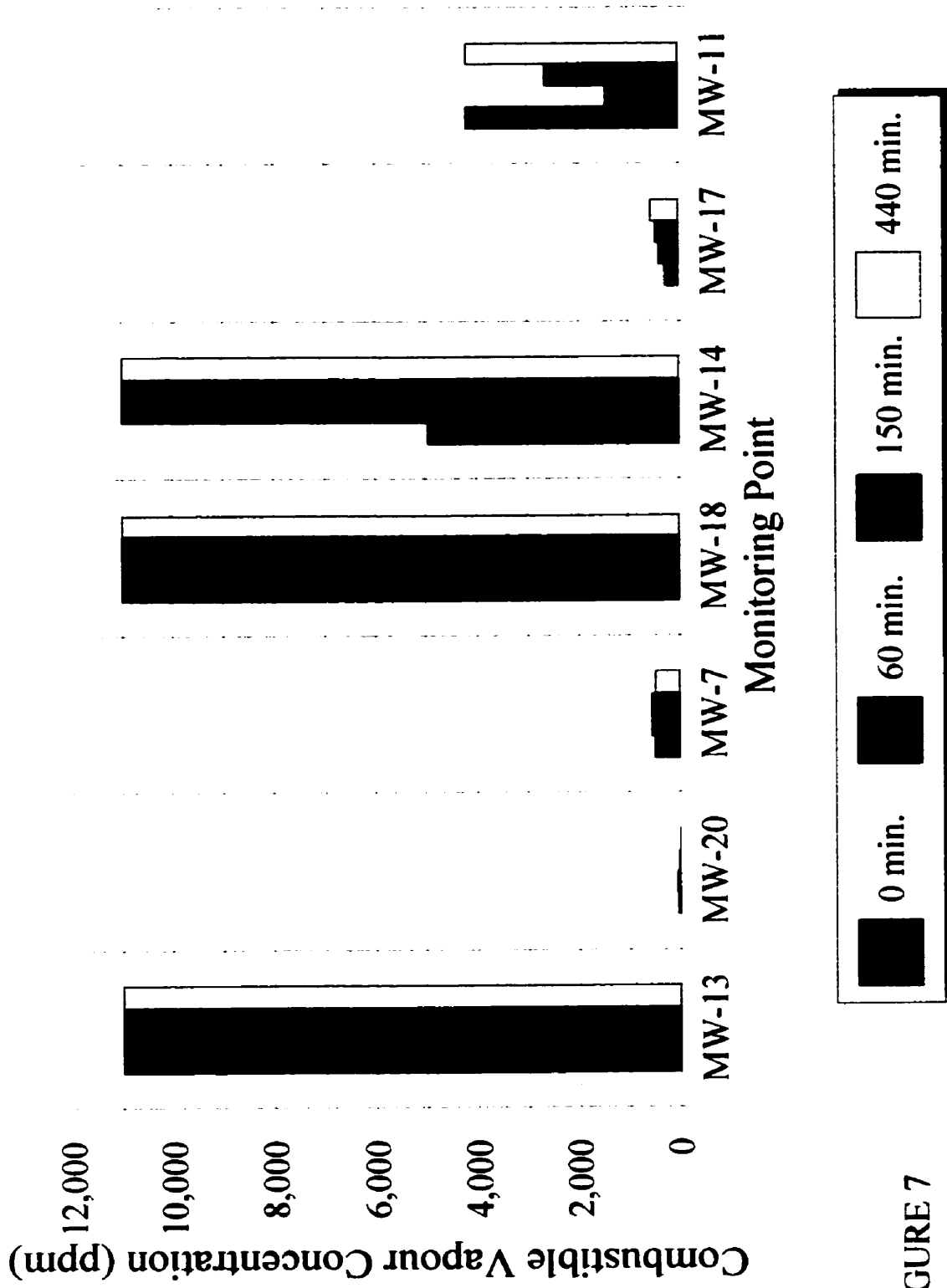

FIGURE 7

Headspace Oxygen Concentrations Test 1

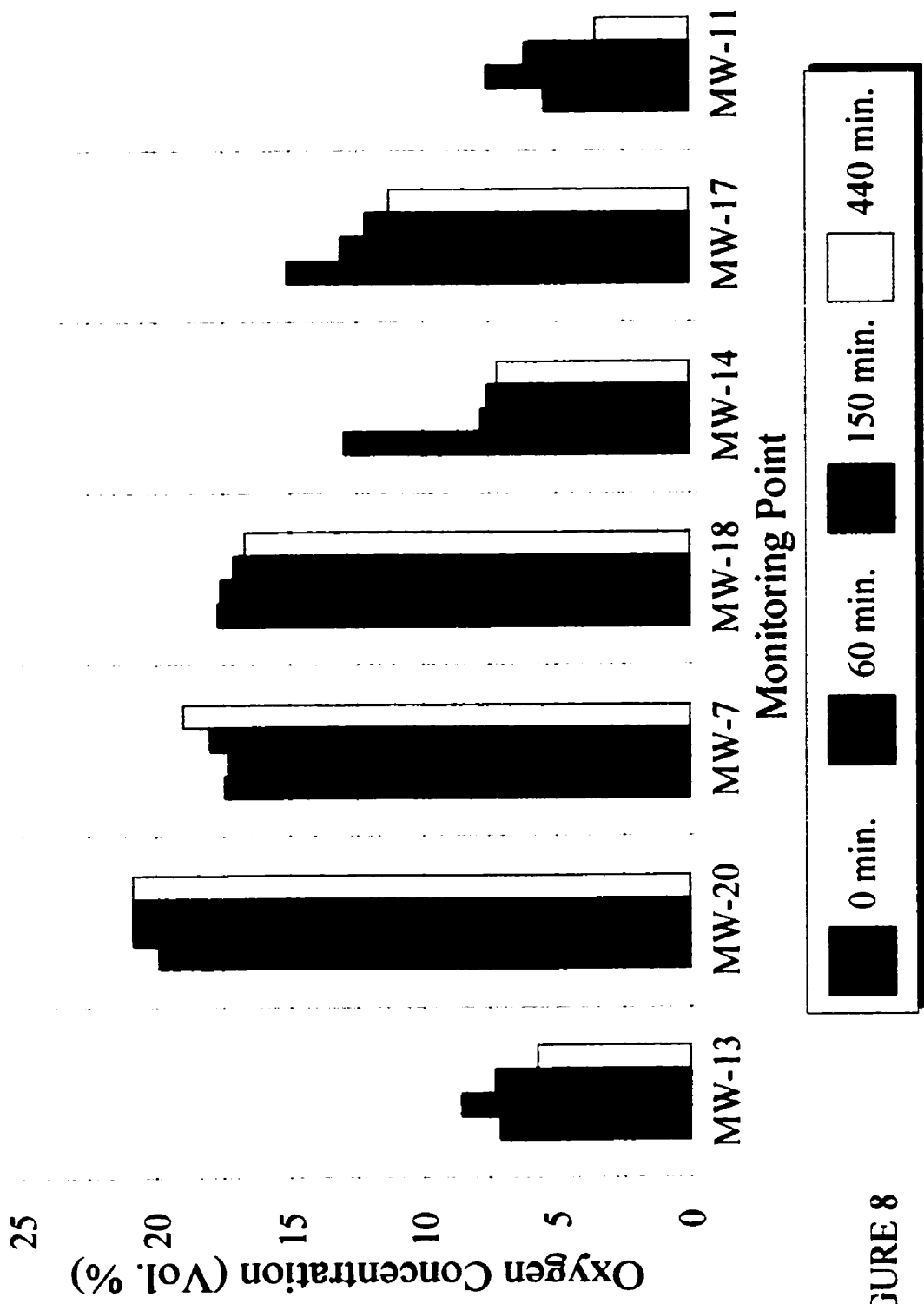

FIGURE 8

Induced Vacuum vs. Distance

Test 1

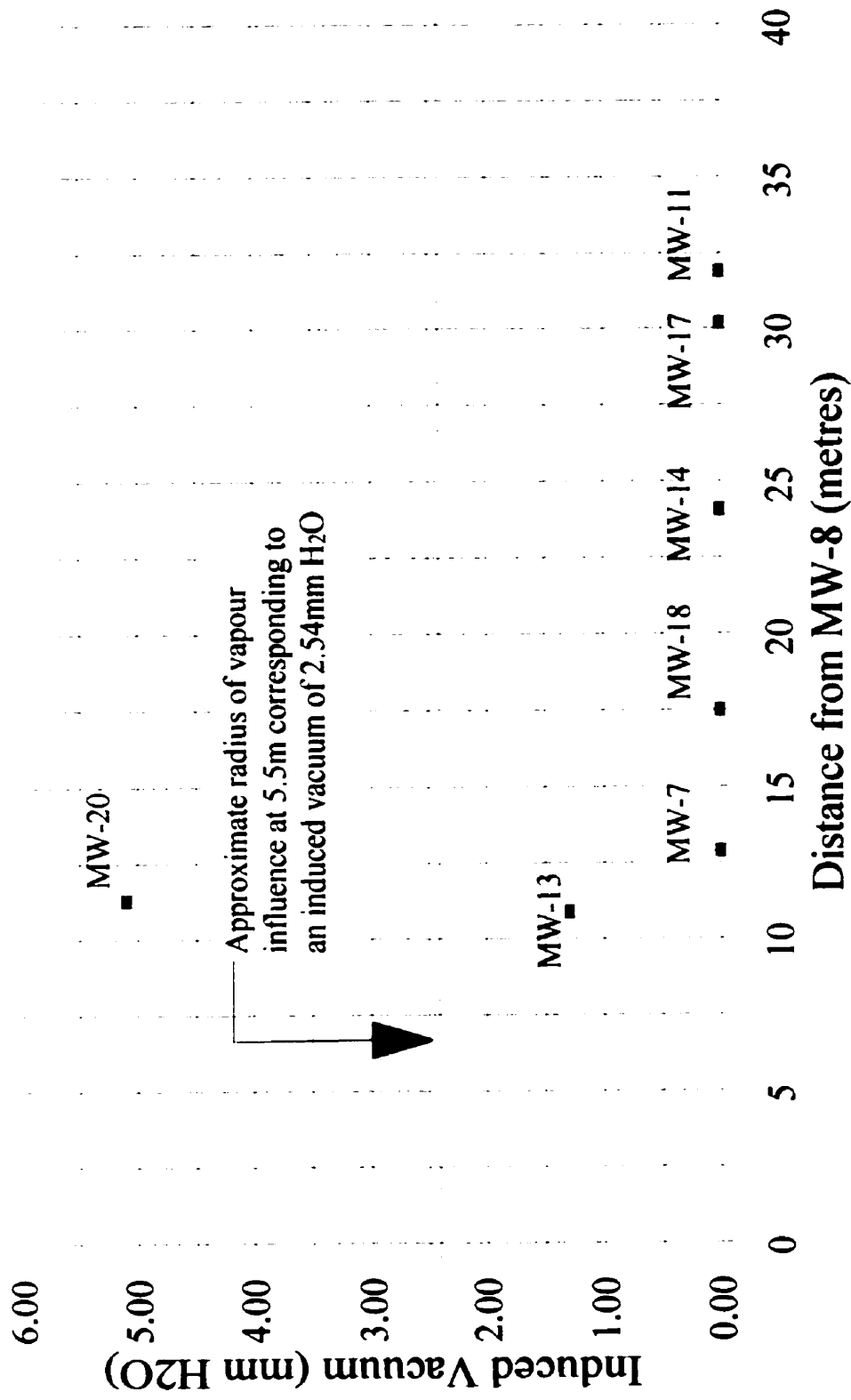
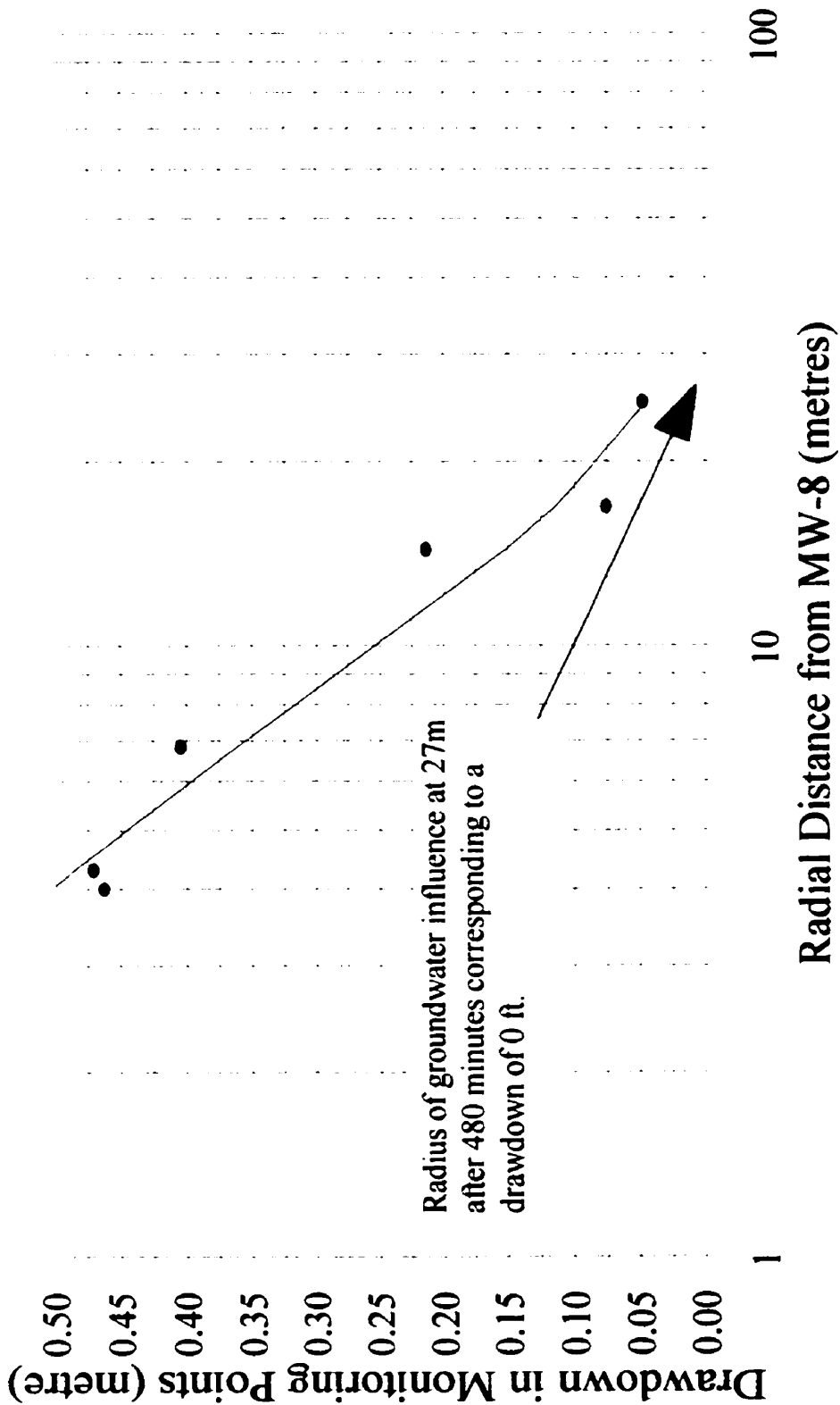

FIGURE 9

Drawdown vs. Distance

Test 1



• Field Data — Exponential Fit

FIGURE 10

Air Flow Rate and Vacuum vs. Time

Test 2

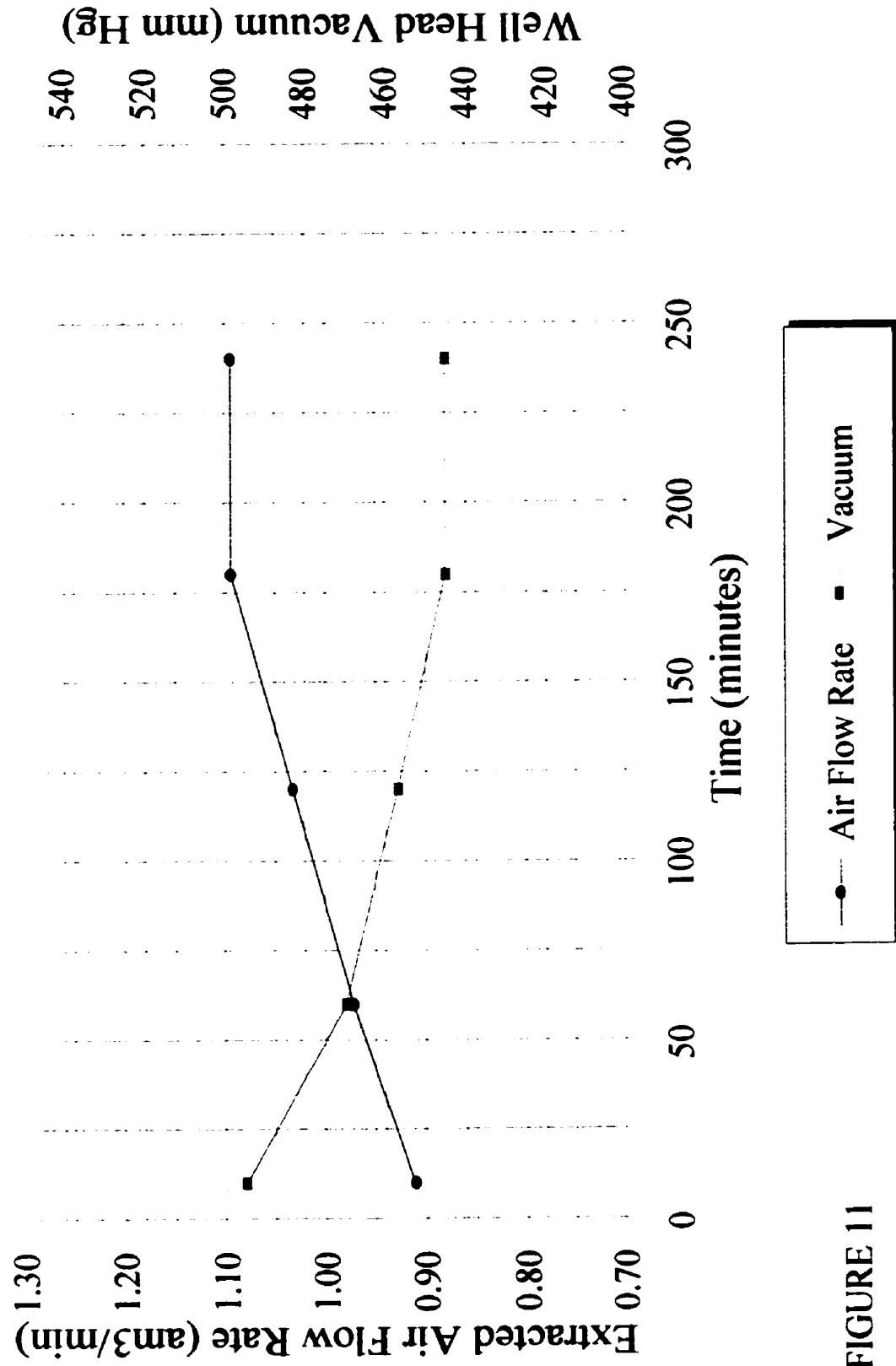

FIGURE 11

Groundwater Flow Rate vs. Time

Test 2

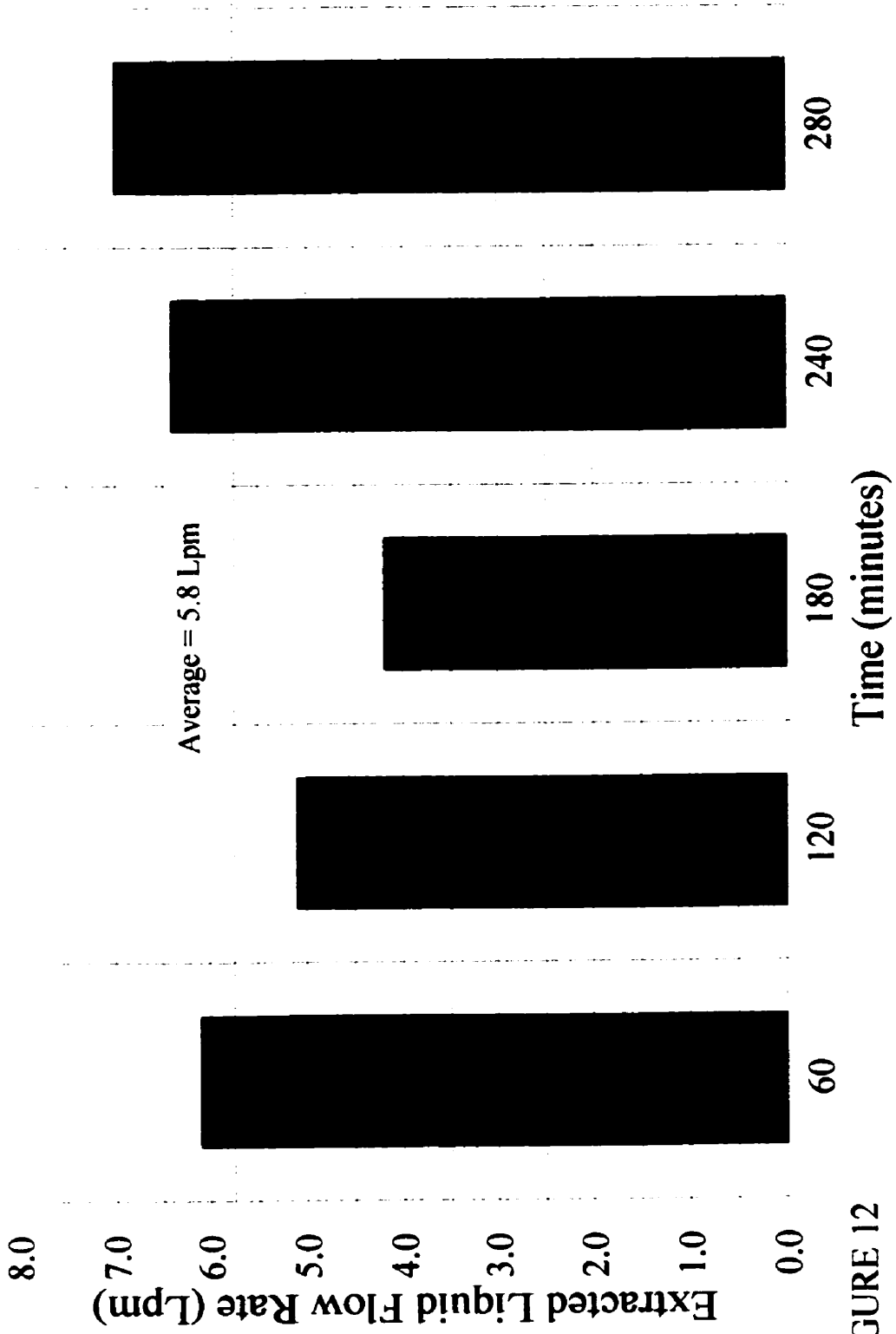

FIGURE 12

Oxygen and Vapour vs. Time

Test 2

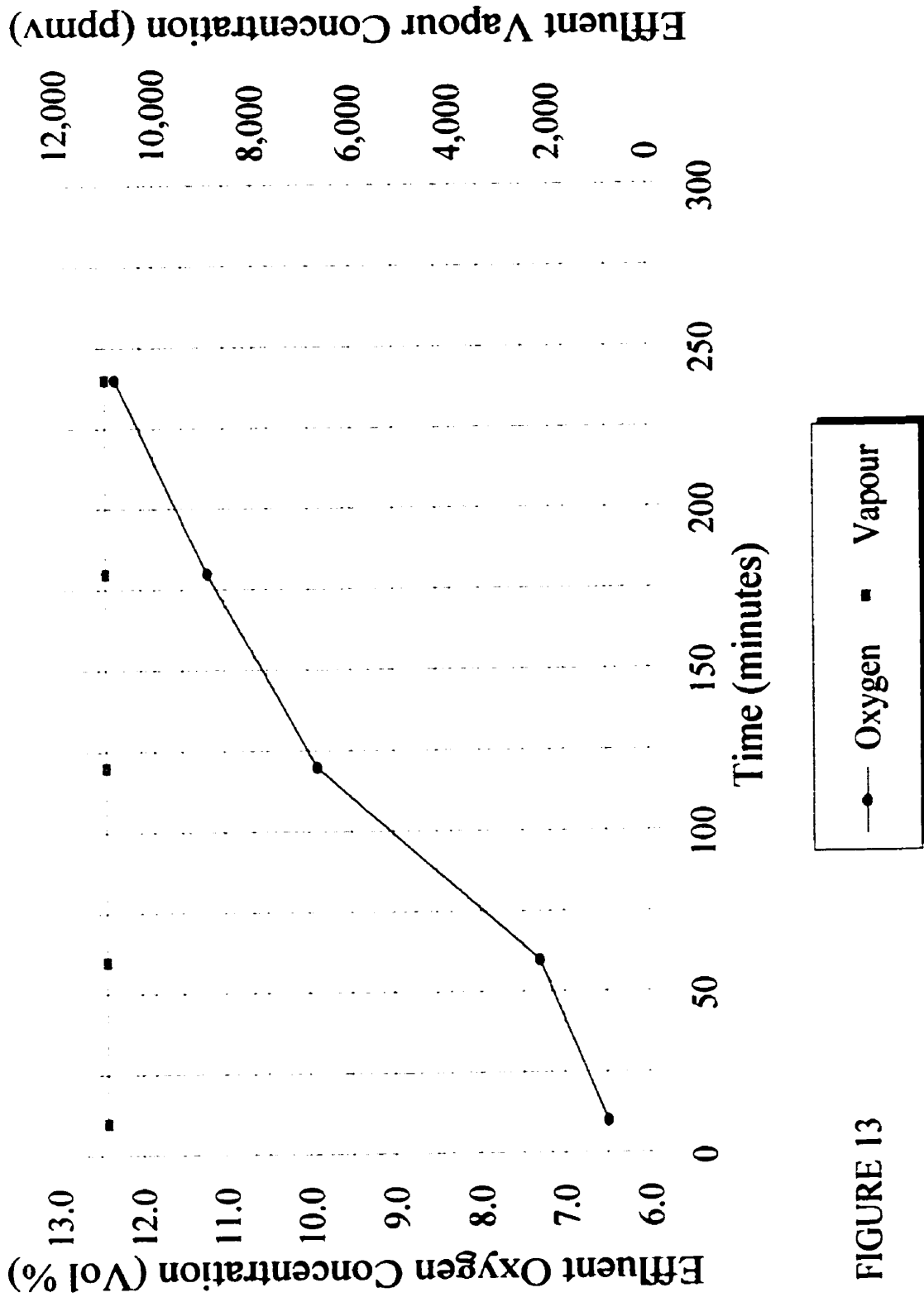

FIGURE 13

Induced Vacuum Test 2

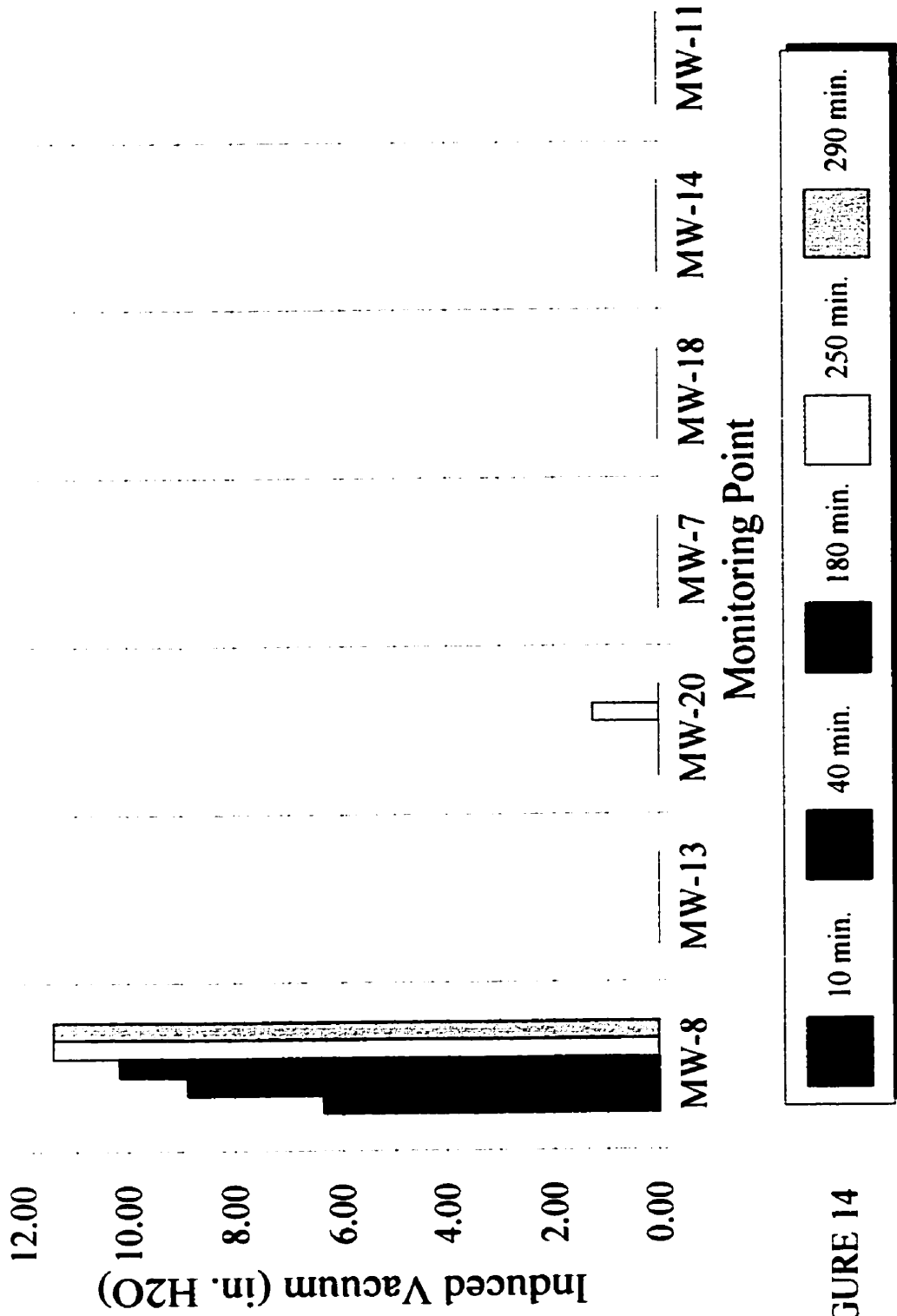

FIGURE 14

Headspace Vapour Concentrations Test 2

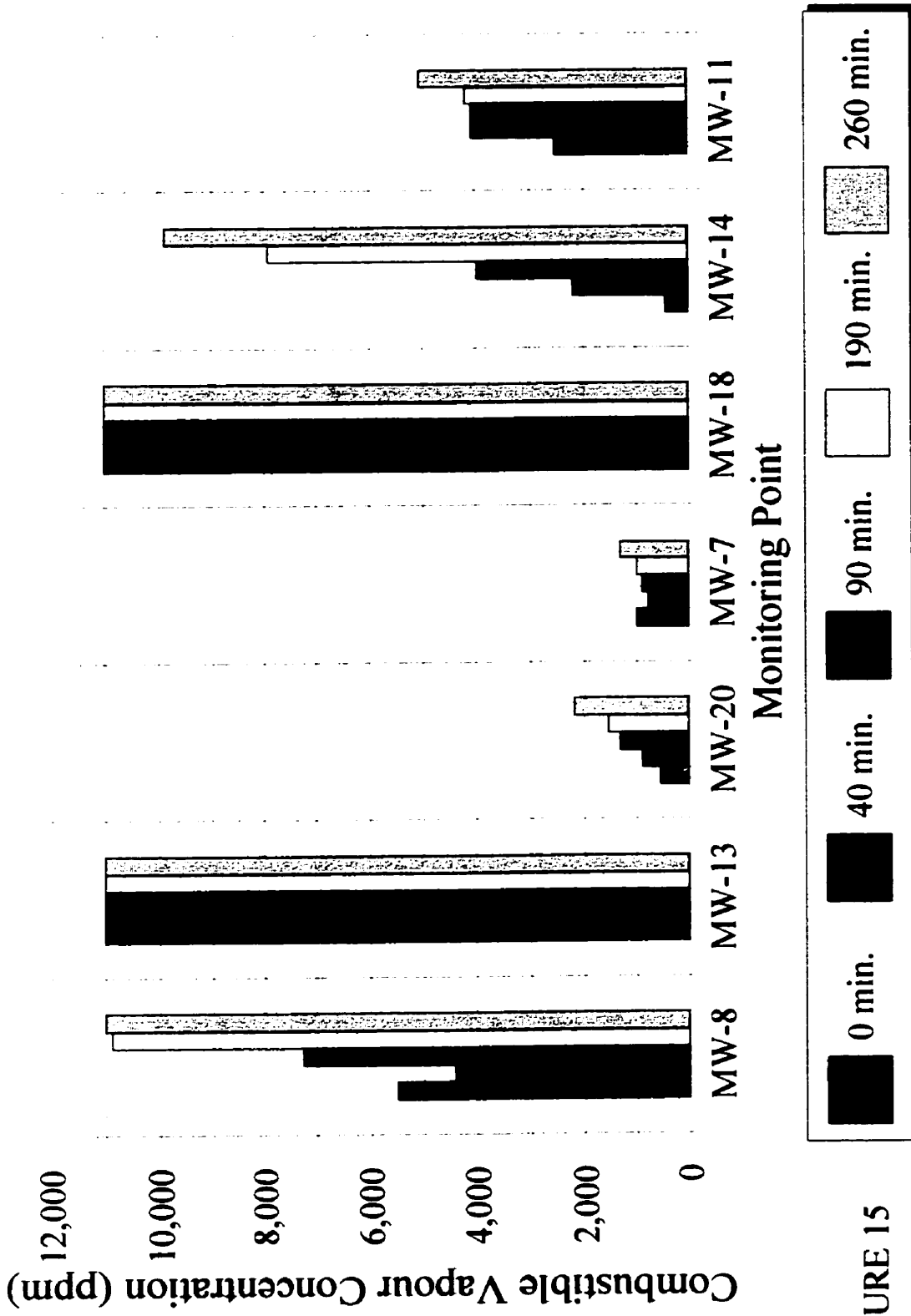

FIGURE 15

Headspace Oxygen Concentrations

Test 2

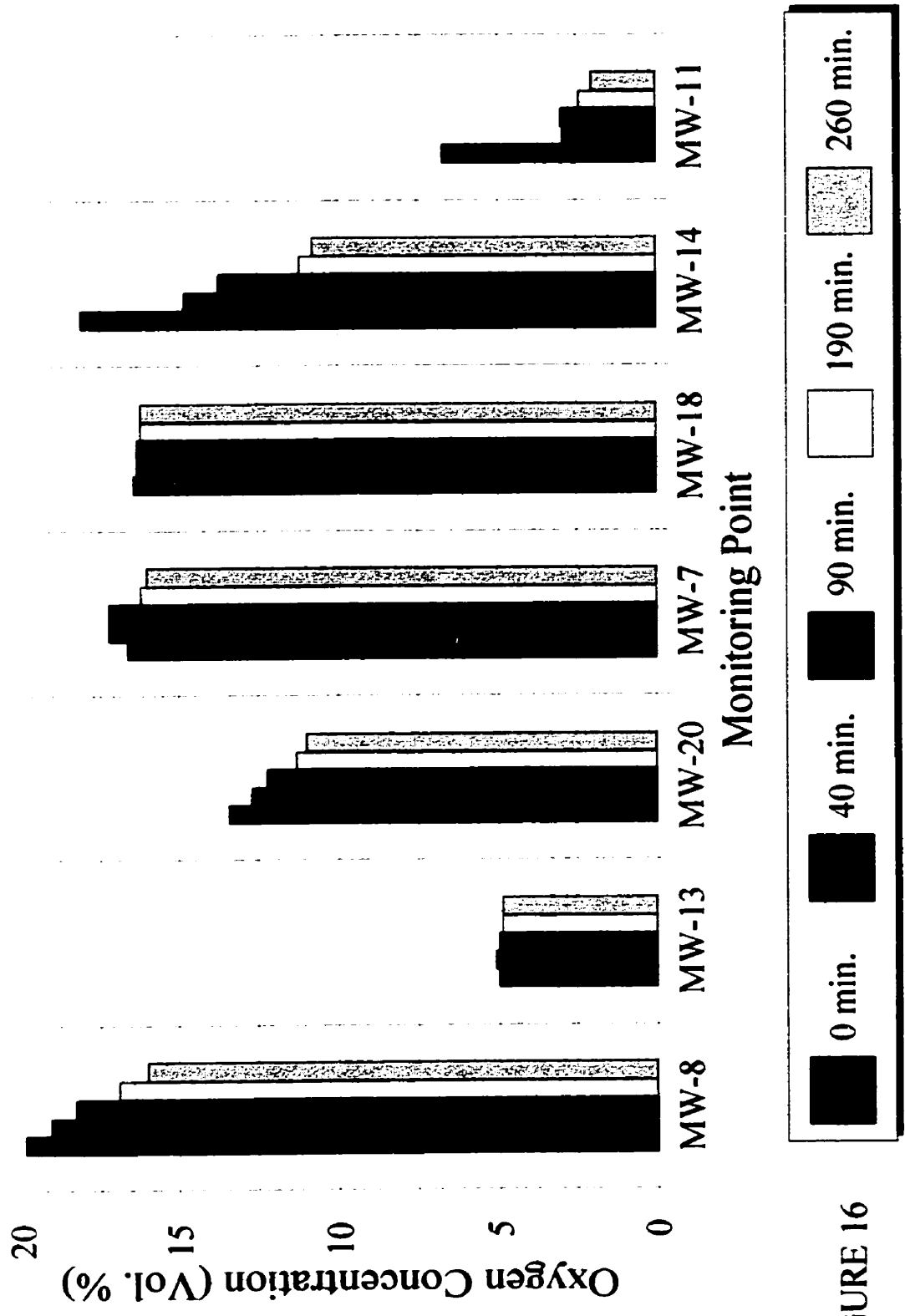

FIGURE 16

Induced Vacuum vs. Distance

Test 2

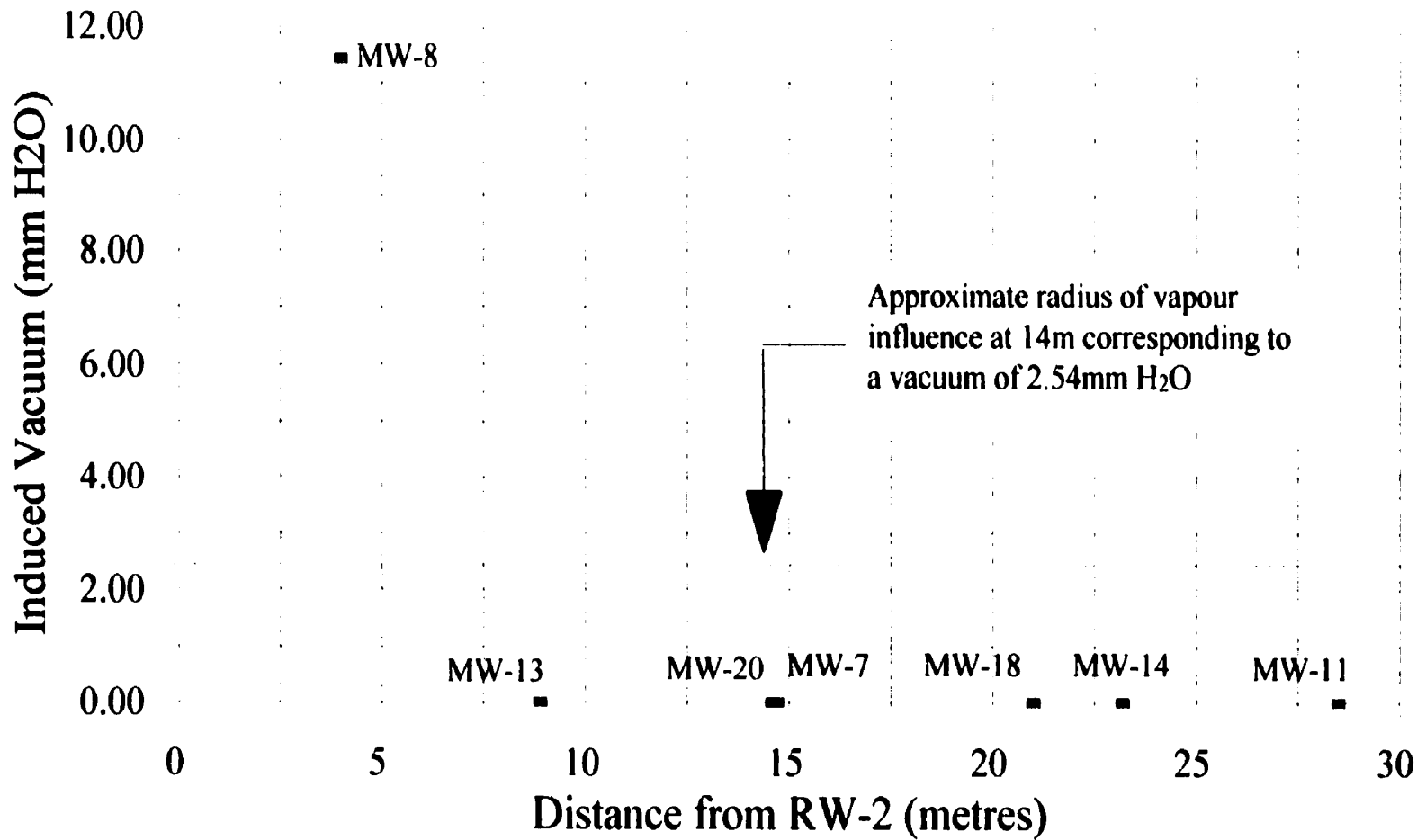

FIGURE 17

Drawdown vs. Distance

Test 2

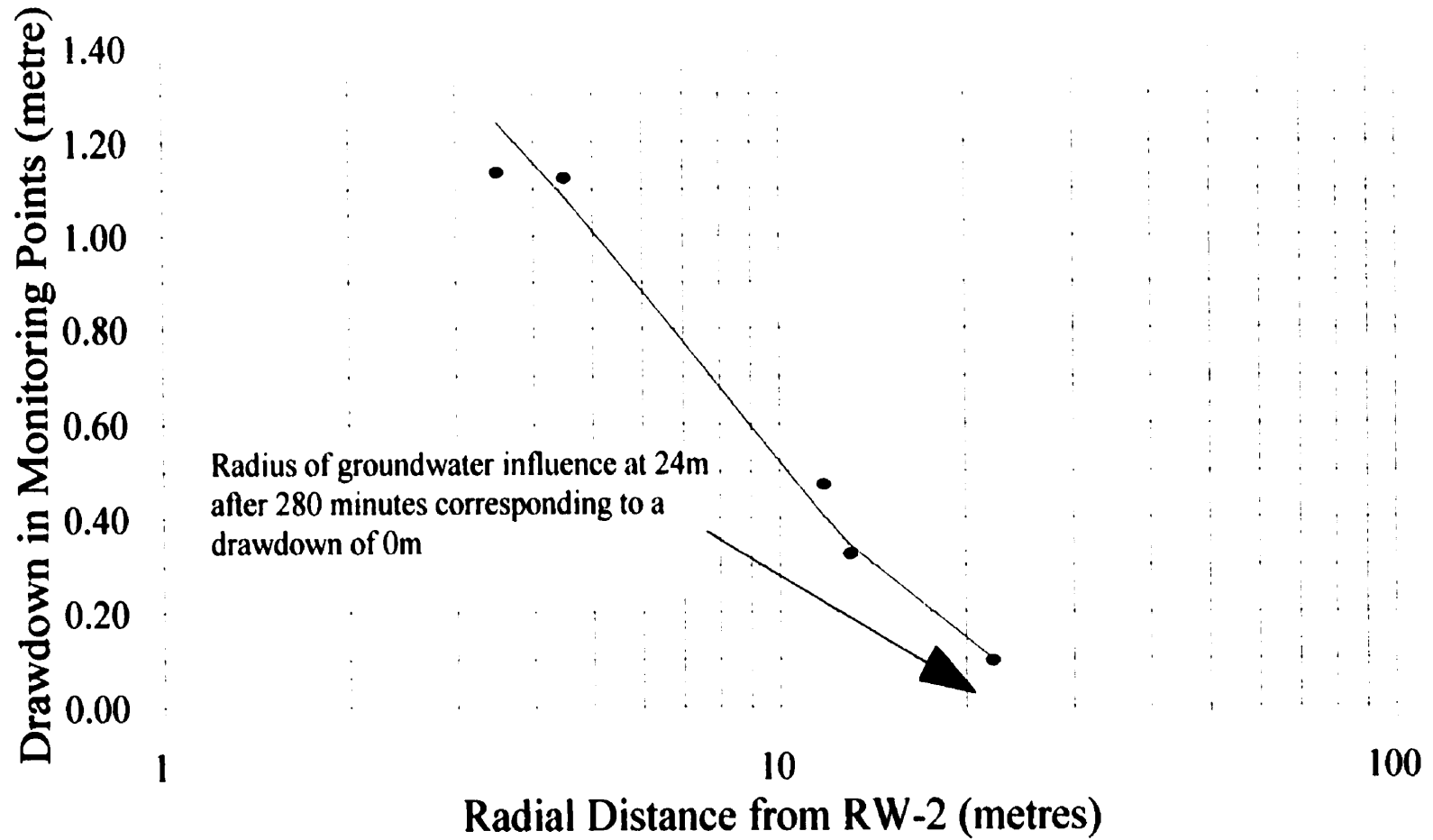
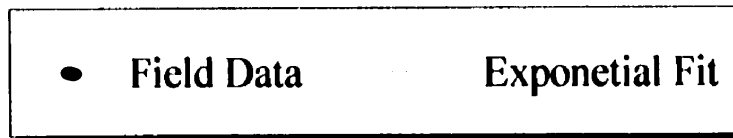
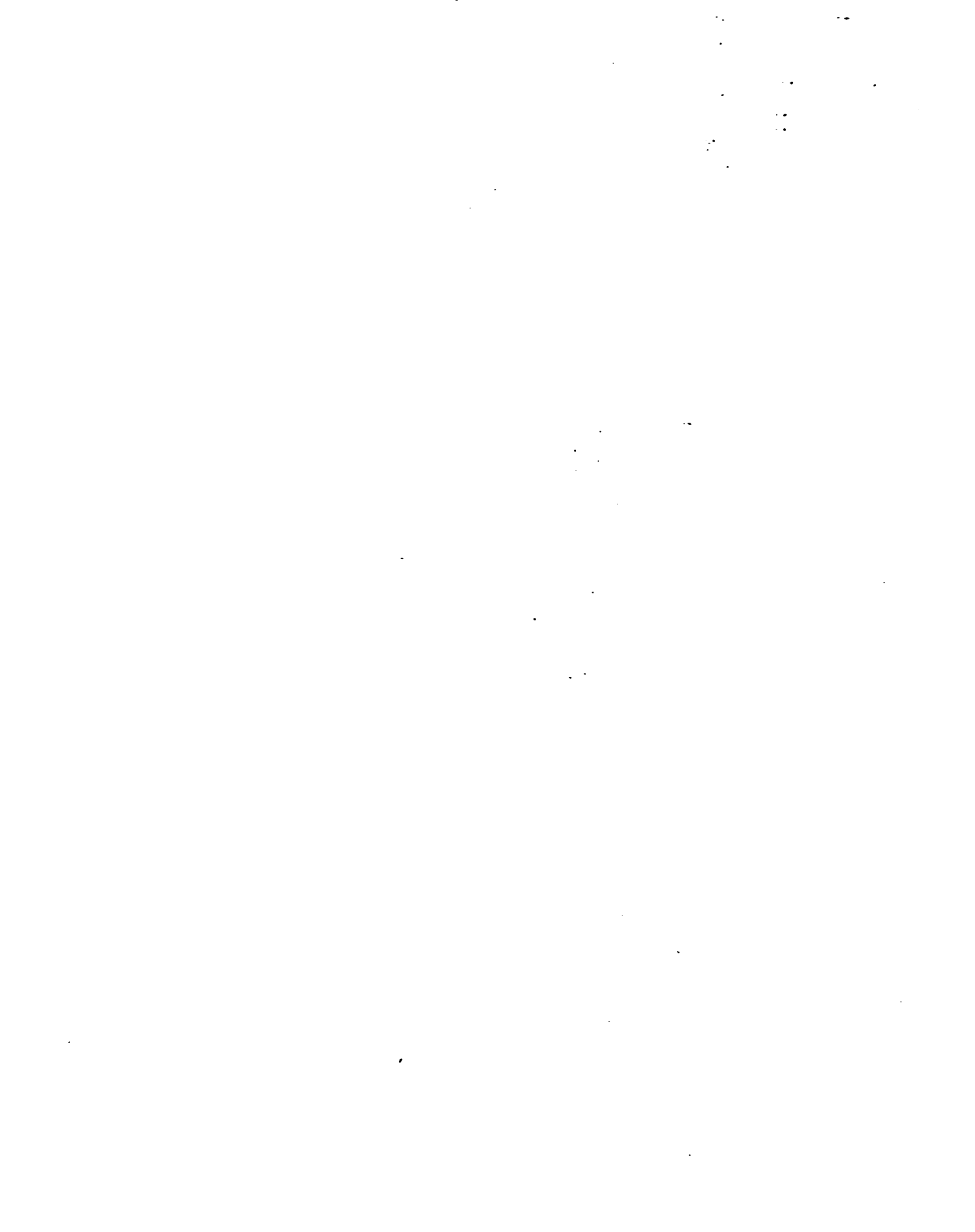
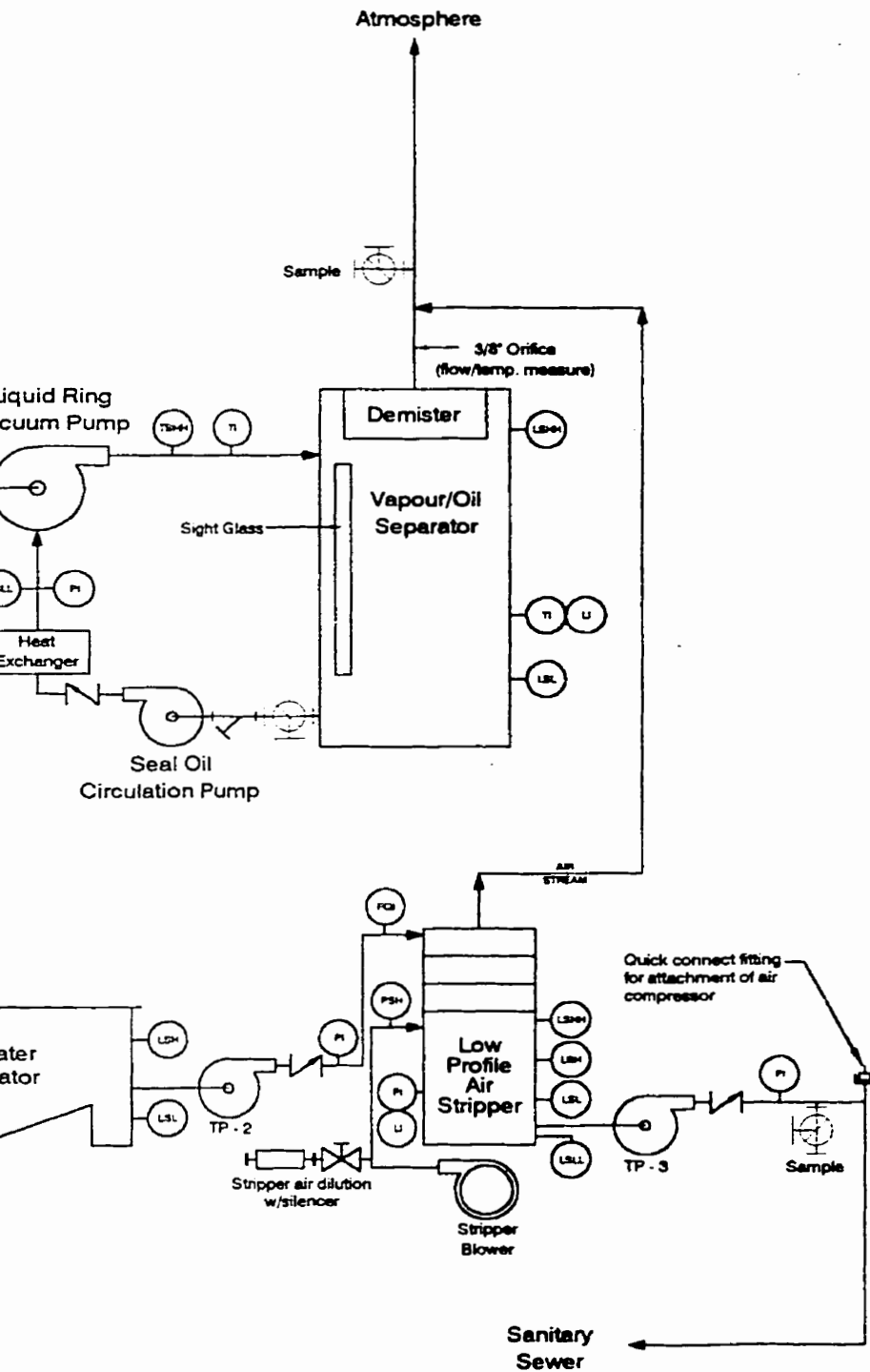

FIGURE 18







NOTES:

- 1) Remediation equipment mounted in a 10' x 15' x 8' high building.
- 2) Electrical: 120/208V, 3 ph., 200 amp (min.), 60 Hz
- 3) Building utilities: lighting, (2) 2 kW heaters, exhaust fan.
- 4) Treated groundwater discharge to sanitary sewer.

LEGEND:

- VI = Vacuum Indicator
- PI = Pressure Indicator
- FI = Flow Indicator
- LSHH = Level Switch High-High
- LSH = Level Switch High
- LSL = Level Switch Low
- LSLL = Level Switch Low-Low
- FSL = Flow Switch Low-Low
- TSHH = Temperature Switch High-High
- TI = Temperature Indicator
- LI = Level Indicator
- PSH = Pressure Switch High
- FQI = Flow Quantity Indicator

Filename	schematic.vcd
Scale	NA
Date	February 15, 2000
Figure No.	19
Bioslurping System Schematic Diagram	

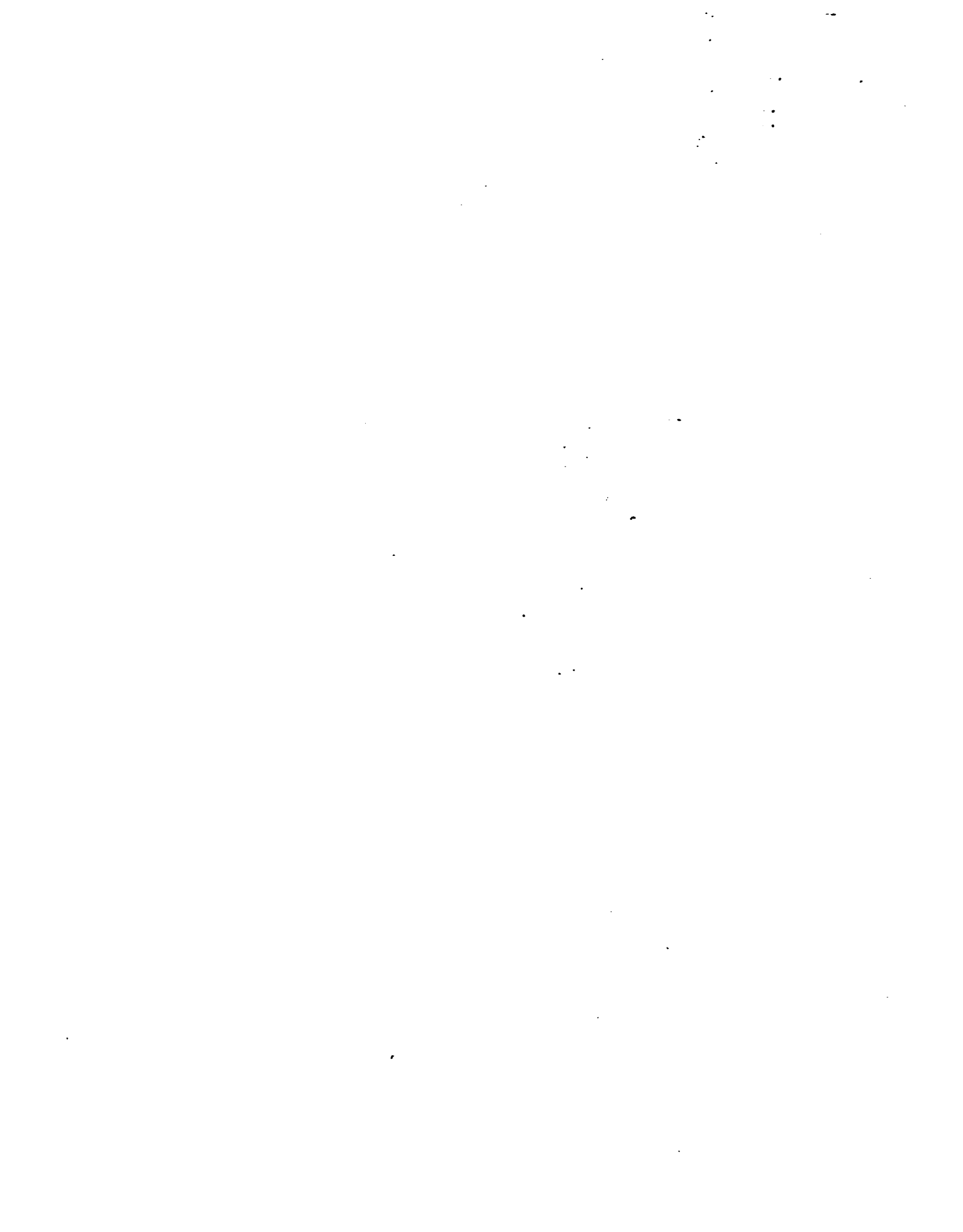

AVENUE

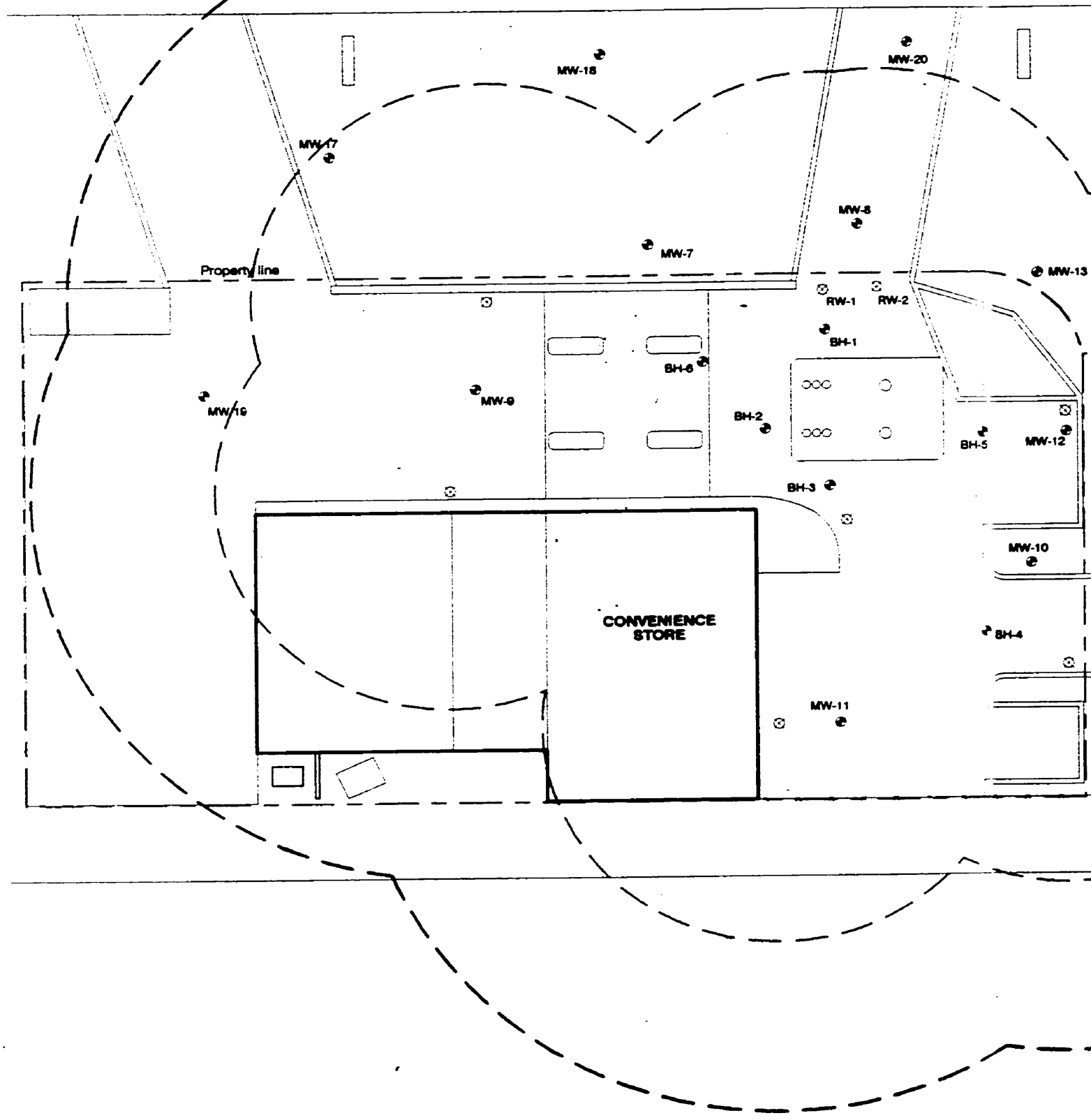

Property line

CONVENIENCE STORE

MW-11

MW-10

MW-12

BH-5

BH-3

BH-2

BH-1

RW-1

RW-2

BH-6

MW-9

MW-16

BH-4

MW-3

MW-18

MW-20

MW-7

MW-7

MW-13

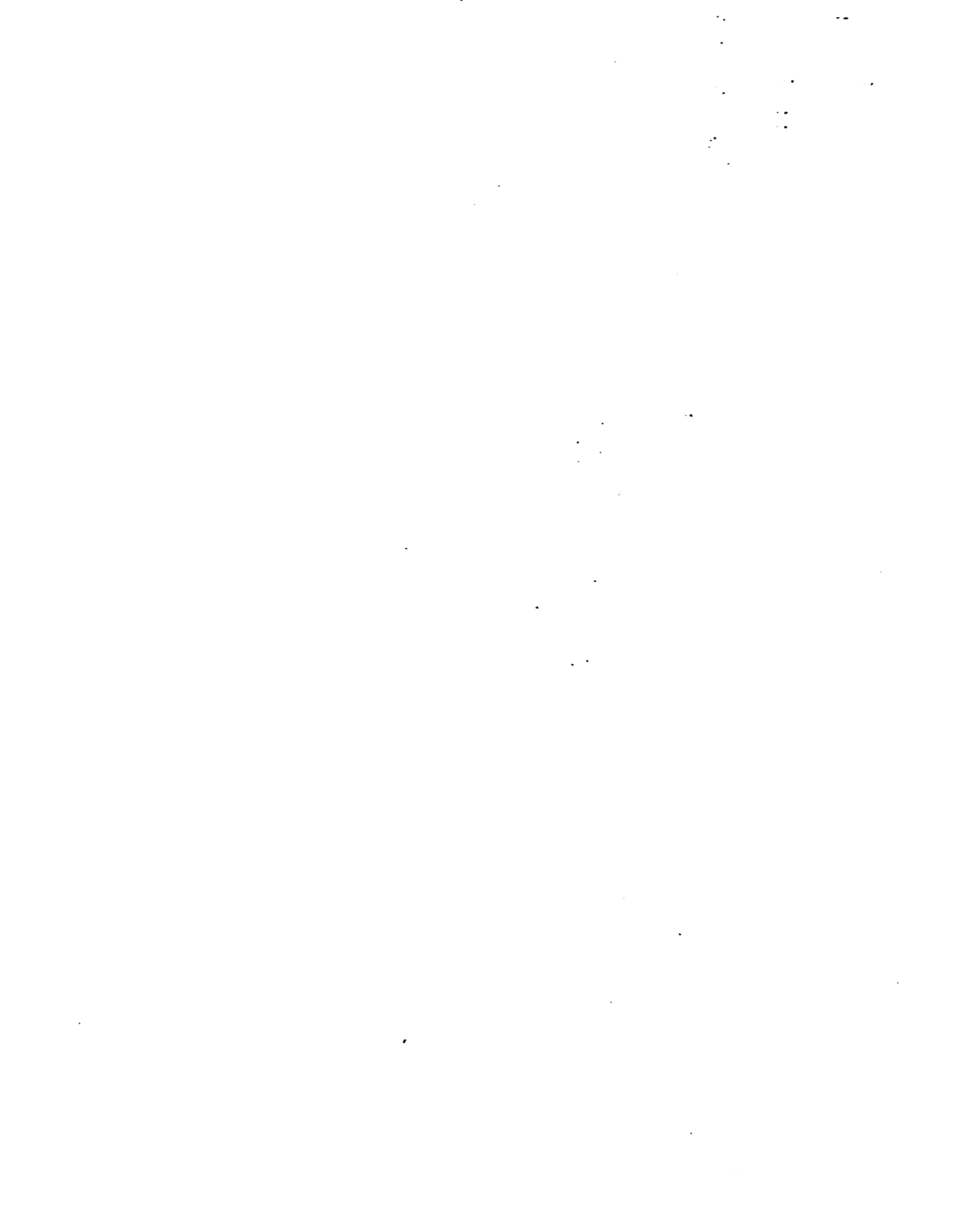



LEGEND:

⊕ *Monitoring Well*

⊙ *Extraction Well*

— — *Predicted Area of Groundwater Influence*

— — *Predicted Area of Vapour Influence*

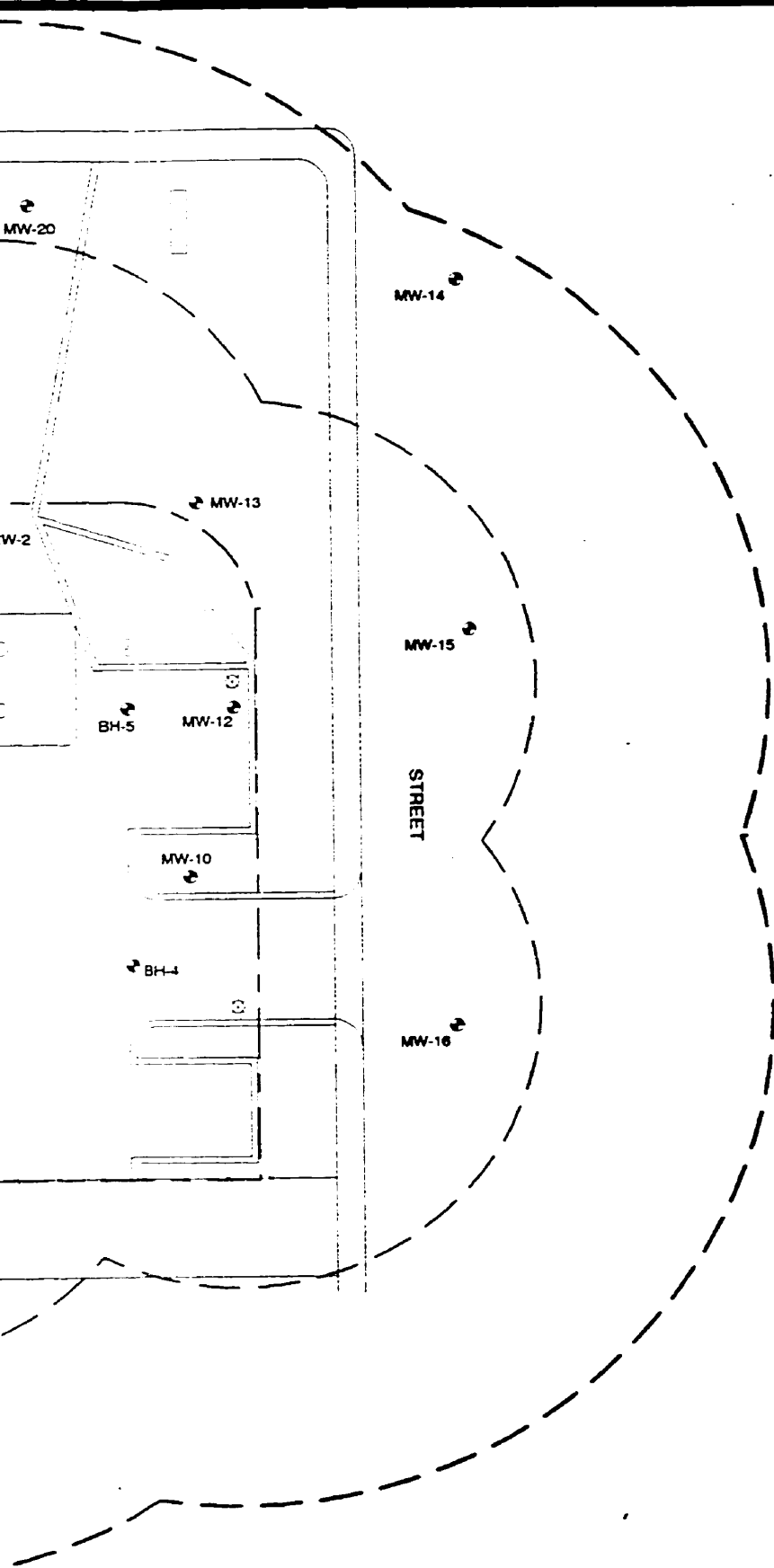

Filename	influence.vcd
----------	---------------

Scale	1" = 25'
-------	----------

Date	February 15, 2000
------	-------------------

Figure No.	20
------------	----

Predicted Areas of Groundwater and Vapour Influence

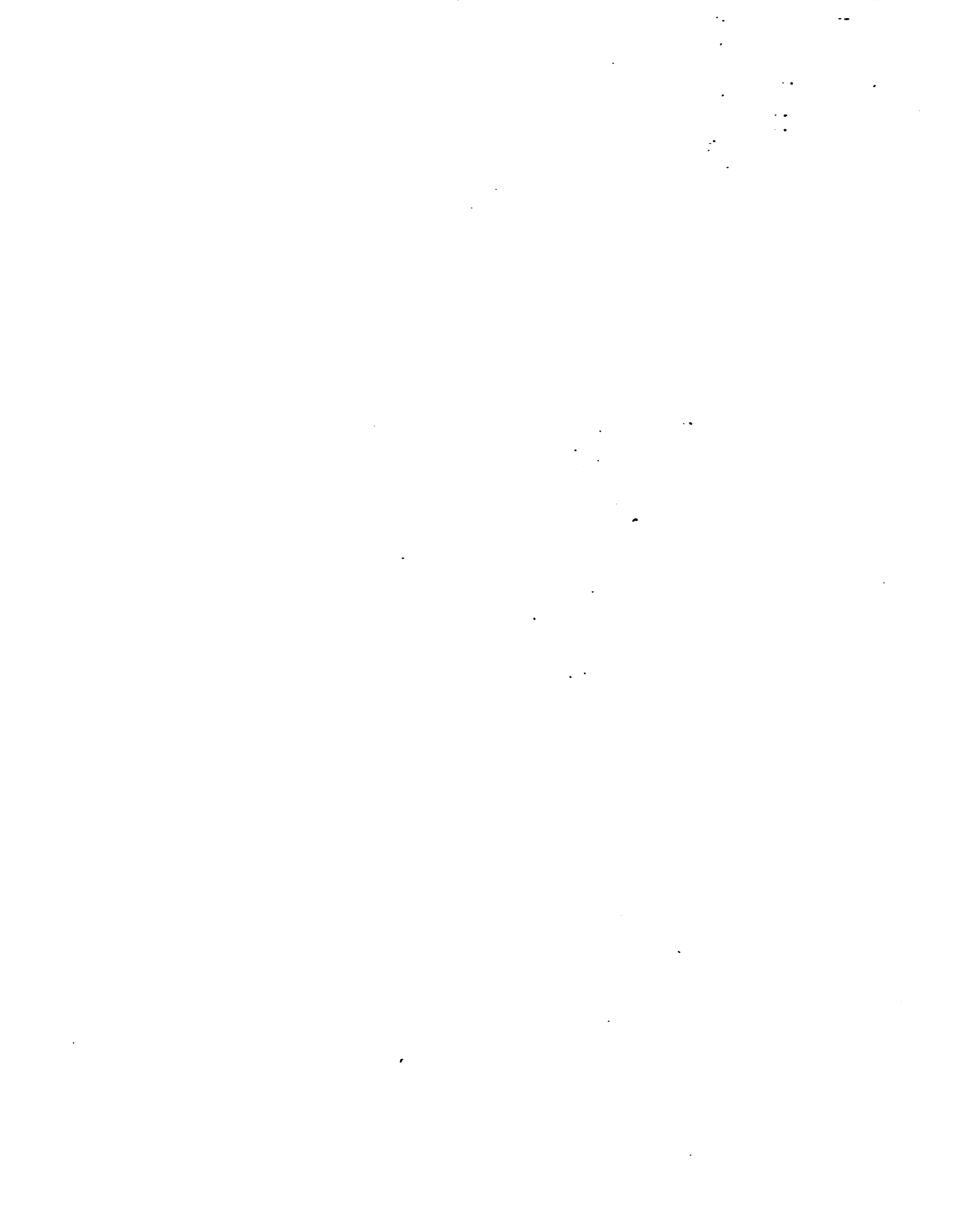

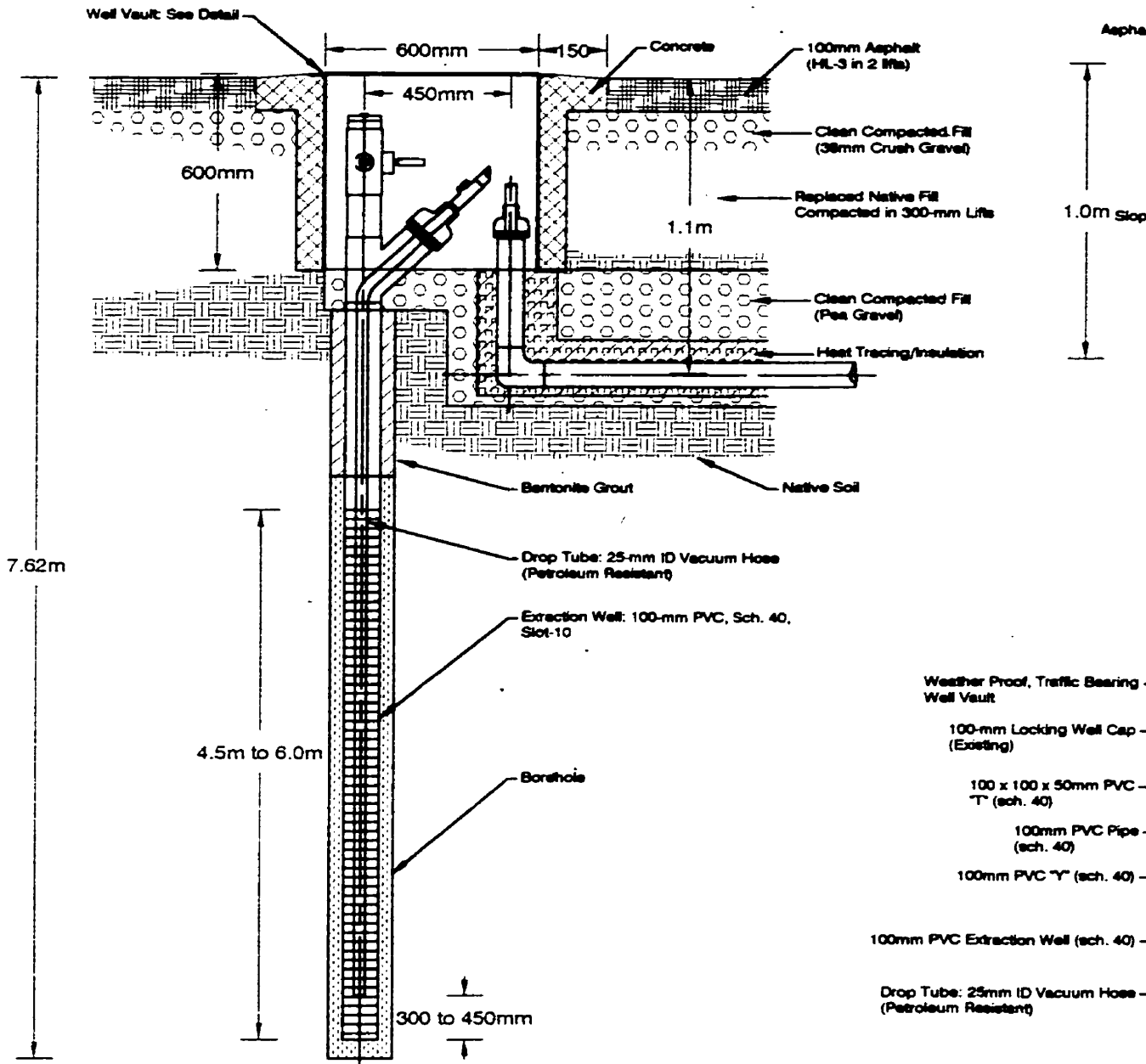

EXTRACTION WELL DETAIL

- Weather Proof, Traffic Bearing - Well Vault
- 100-mm Locking Well Cap - (Existing)
- 100 x 100 x 50mm PVC - "T" (sch. 40)
- 100mm PVC Pipe - (sch. 40)
- 100mm PVC "Y" (sch. 40)
- 100mm PVC Extraction Well (sch. 40)
- Drop Tube: 25mm ID Vacuum Hose - (Petroleum Resistant)

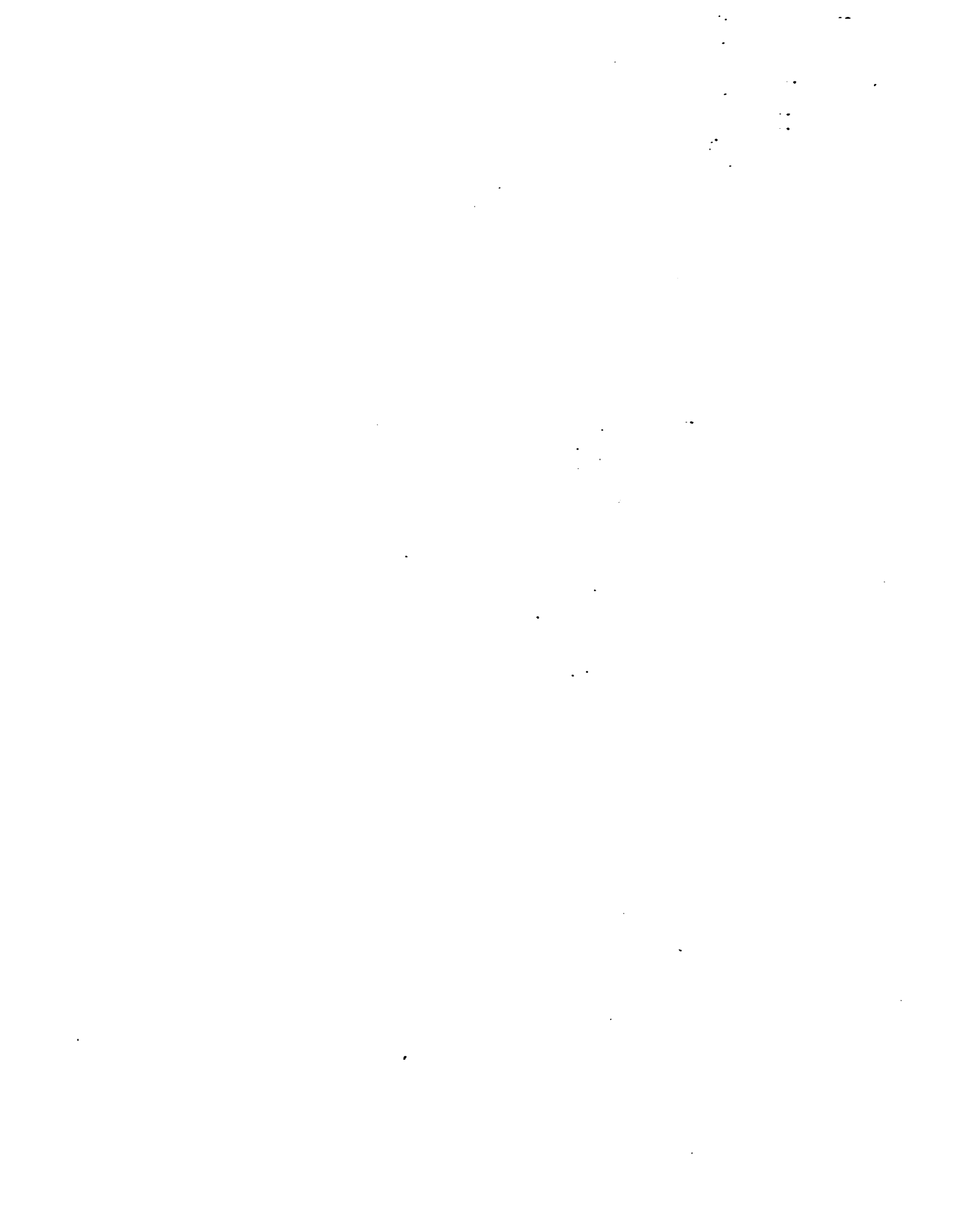

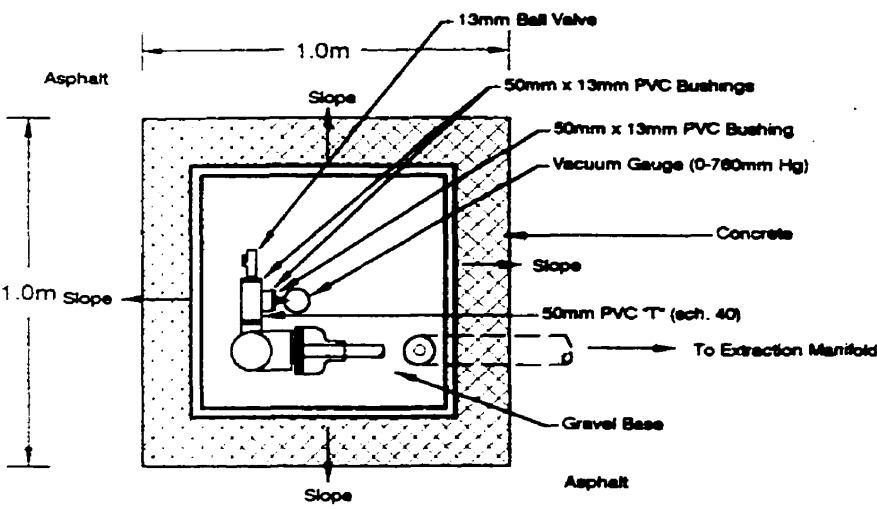

**EXTRACTION WELL VAULT
PLAN VIEW**

NOTES:

- 1) Heat tracing and insulation shall extend into the well vaults to protect the exposed section of the vacuum hose from freezing.

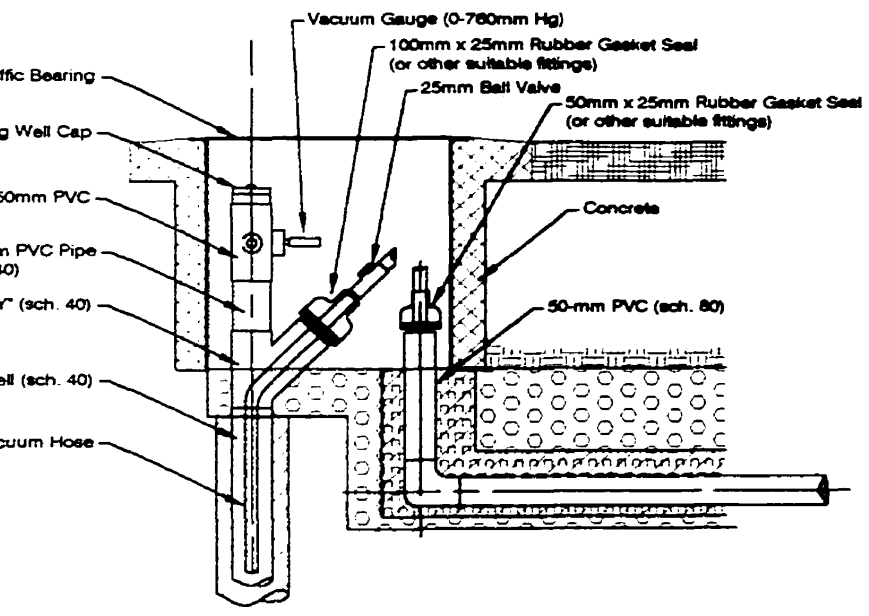

EXTRACTION WELL VAULT DETAIL

Filename	well details.vcd
Scale	Not to Scale
Date	February 15, 2000
Figure No.	21
Extraction Well Details	

